



Teledif Italia srl

Lift Monitoring & Diagnostics System

LIFT UNIT ver. 7.2

OPERATION MANUAL

465213.270 OM

(rev. 23)

Torino 2022

CONTENT

DESCRIPTION AND FUNCTIONING OF the LIFT UNIT.....	4
Purpose	4
Specification	9
Use of a lift unit	26
Lift unit operation.....	26
Operational testing.....	30
Maintenance	32
General terms.....	32
Safety precautions	32
Quarterly maintenance	32
Running repair	33
Storage	34
Transportation.....	35
APPENDIX A	36
Table 1 The LU 7.2 Status formation algorithm	36
Table 2 Lift unit parameters	38
Table 3. Service codes.....	40
Table 4. interval code correspondence to the real time.....	42
Table 5 Mapping of USER1...USER4 and OUT1 onto the LU checkpoints	43
APPENDIX B	45
Table 1. Complete set of LU ver. 7.2 depending on design version	45
APPENDIX C	53
LU 7.2 input/output types and their usage	53
APPENDIX D	54
Voice notification possible combination	54
APPENDIX E	55
Correspondence of interface cards to Lift Unit 7.2 options.....	55

This manual is intended to learn the Lift Unit ver. 7.2 of Lift Monitoring and Diagnostics System (LMDS), its performance and operating rules (use, transportation, storage and maintenance) for the purpose of correct handling.

Installation, operation, maintenance, repairing, modernization and replacement of LMDS must be performed by service contractor using appropriate technical equipment and qualified personnel.

The present manual covers all options of lift unit ver. 7.2.

During operation of the lift unit of LMDS it is required to follow the recommendations of the present manual as well as of other documents provided by the manufacturer of LMDS.

The following terms and abbreviations are used in the manual:

- EEPROM: nonvolatile memory;
- RSA: relay station adaptor;
- CD: cabin door;
- LD: landing door;
- SC: short circuit;
- LU: lift unit version 7.2;
- MR: machine room;
- PC: personal computer;
- LCU: lift control unit;
- TM: technical maintenance;
- SD: safety device;
- OGS: overspeed governor sensor.

DESCRIPTION AND FUNCTIONING OF THE LIFT UNIT

Purpose

Lift unit of options 465213.270-10...465213.270-12, 465213.270-14... 465213.270-117 is the main part of the Lift Monitoring & Diagnostic System.

Lift units options are shown in Table 1.

Table 1

Name	Short name	Designation
Lift unit ver. 7.2 – R	LU 7.2 - R	465213.270-10
Lift unit ver. 7.2 «OTIS»	LU 7.2 «OTIS»	465213.270-11
Lift unit ver. 7.2 «SHULK-17»	LU 7.2 «SHULK-17»	465213.270-12
Lift unit ver. 7.2 «SHULK-32»	LU 7.2 «SHULK-32»	465213.270-14
Lift unit ver. 7.2 «UKL/UL»	LU 7.2 «UKL/UL»	465213.270-15
Lift unit ver. 7.2 «NKU-MPPL»	LU 7.2 «NKU-MPPL»	465213.270-16
Lift unit ver. 7.2 «UUL»	LU 7.2 «UUL»	465213.270-17
Lift unit ver. 7.2 «SODIMAS»	LU 7.2 «SODIMAS»	465213.270-18
Lift unit ver. 7.2 «SUL»	LU 7.2 «SUL»	465213.270-19
Lift unit ver. 7.2 «LG»	LU 7.2 «LG»	465213.270-20
Lift unit ver. 7.2 «ESK»	LU 7.2 «ESK»	465213.270-21
Lift unit ver. 7.2 «AXEL»	LU 7.2 «AXEL»	465213.270-22
Lift unit ver. 7.2 «ELEX»	LU 7.2 «ELEX»	465213.270-23
Lift unit ver. 7.2 «THYSSEN»	LU 7.2 «THYSSEN»	465213.270-24
Lift unit ver. 7.2 «SPUL»	LU 7.2 «SPUL»	465213.270-25
Lift unit ver. 7.2 «OLYMPUS»	LU 7.2 «OLYMPUS»	465213.270-26
Lift unit ver. 7.2 «KLEEMANN»	LU 7.2 «KLEEMANN»	465213.270-27
Lift unit ver. 7.2 «DOPPLER»	LU 7.2 «DOPPLER»	465213.270-28
Lift unit ver. 7.2 «BLT»	LU 7.2 «BLT»	465213.270-29
Lift unit ver. 7.2 «EXPRESS»	LU 7.2 «EXPRESS»	465213.270-30
Lift unit ver. 7.2 «THYSSEN TAC50»	LU 7.2 «THYSSEN TAC50»	465213.270-31
Lift unit ver. 7.2 «SCHINDLER»	LU 7.2 «SCHINDLER»	465213.270-32
Lift unit ver. 7.2 «BG-15»	LU 7.2 «BG-15»	465213.270-33
Lift unit ver. 7.2 «ORONA»	LU 7.2 «ORONA»	465213.270-34
Lift unit ver. 7.2 «NKU-MPPL BPSH-2»	LU 7.2 «NKU-MPPL BPSH2»	465213.270-35
Lift unit ver. 7.2 «ARKEL»	LU 7.2 «ARKEL»	465213.270-36
Lift unit ver. 7.2 «SODIMAS QI»	LU 7.2 «SODIMAS QI»	465213.270-37
Lift unit ver. 7.2 «TP»	LU 7.2 «TP»	465213.270-38
Lift unit ver. 7.2 «ORONA ARCA1»	LU 7.2 «ORONA ARCA1»	465213.270-39
Lift unit ver. 7.2 «DMG»	LU 7.2 «DMG»	465213.270-40
Lift unit ver. 7.2 «MIK-EL»	LU 7.2 «MIK-EL»	465213.270-41
Lift unit ver. 7.2 «KONE»	LU 7.2 «KONE»	465213.270-42
Lift unit ver. 7.2 «VEGA»	LU 7.2 «VEGA»	465213.270-43
Lift unit ver. 7.2 «HYUNDAI»	LU 7.2 «HYUNDAI»	465213.270-44
Lift unit ver. 7.2 «NICE»	LU 7.2 «NICE»	465213.270-45
Lift unit ver. 7.2 «S9»	LU 7.2 «S9»	465213.270-46
Lift unit ver. 7.2 «AC-01»	LU 7.2 «AC-01»	465213.270-47
Lift unit ver. 7.2 «iAStar»	LU 7.2 «iAStar»	465213.270-48
Lift unit ver. 7.2 «FST2»	LU 7.2 «FST2»	465213.270-49
Lift unit ver. 7.2 «CANNY»	LU 7.2 «CANNY»	465213.270-50
Lift unit ver. 7.2 «SILVER»	LU 7.2 «SILVER»	465213.270-51

Name	Short name	Designation
Lift unit ver. 7.2 «DOPPLER ACT»	LU 7.2 «DOPPLER ACT»	465213.270-52
Lift unit ver. 7.2 «INV»	LU 7.2 «INV»	465213.270-53
Lift unit ver. 7.2 «E9»	LU 7.2 «E9»	465213.270-54
Lift unit ver. 7.2 «ECLIPSE»	LU 7.2 «ECLIPSE»	465213.270-55
Lift unit ver. 7.2 «VASSLER»	LU 7.2 «VASSLER»	465213.270-56
Lift unit ver. 7.2 «TMS600»	LU 7.2 «TMS600»	465213.270-57
Lift unit ver. 7.2 «BETACONTROL»	LU 7.2 «BETACONTROL»	465213.270-58
Lift unit ver. 7.2 «CARLOS SILVA»	LU 7.2 «CARLOS SILVA»	465213.270-59
Lift unit ver. 7.2 «ShK6000»	LU 7.2 «SHK6000»	465213.270-60
Lift unit ver. 7.2 «TKL»	LU 7.2 «TKL»	465213.270-61
Lift unit ver. 7.2 «SOYUZ»	LU 7.2 «SOYUZ»	465213.270-62
Lift unit ver. 7.2 «LLC»	LU 7.2 «LLC»	465213.270-63
Lift unit ver. 7.2 «SHL-R»	LU 7.2 «SHL-R»	465213.270-64
Lift unit ver. 7.2 «FT9x0»	LU 7.2 «FT9x0»	465213.270-65
Lift unit ver. 7.2 «VEK»	LU 7.2 «VEK»	465213.270-66
Lift unit ver. 7.2 «KOLLMORGEN»	LU 7.2 «KOLLMORGEN»	465213.270-67
Lift unit ver. 7.2 «THYSSEN CMC»	LU 7.2 «THYSSEN CMC»	465213.270-68
Lift unit ver. 7.2 «SECURLIFT»	LU 7.2 «SECURLIFT»	465213.270-69
Lift unit ver. 7.2 «THYSSEN MCI»	LU 7.2 «THYSSEN MCI»	465213.270-70
Lift unit ver. 7.2 «WIPO»	LU 7.2 «WIPO»	465213.270-71
Lift unit ver. 7.2 «KLST»	LU 7.2 «KLST»	465213.270-72
Lift unit ver. 7.2 «ELCO MICRO»	LU 7.2 «ELCO MICRO»	465213.270-73
Lift unit ver. 7.2 «KOYO»	LU 7.2 «KOYO»	465213.270-74
Lift unit ver. 7.2 «BL6»	LU 7.2 «BL6»	465213.270-75
Lift unit ver. 7.2 «WEBER»	LU 7.2 «WEBER»	465213.270-76
Lift unit ver. 7.2 «GTE»	LU 7.2 «GTE»	465213.270-77
Lift unit ver. 7.2 «DAESUNG»	LU 7.2 «DAESUNG»	465213.270-78
Lift unit ver. 7.2 «ML65X»	LU 7.2 «ML65X»	465213.270-79
Lift unit ver. 7.2 «SKG»	LU 7.2 «SKG»	465213.270-80
Lift unit ver. 7.2 «ISL»	LU 7.2 «ISL»	465213.270-81
Lift unit ver. 7.2 «ML60X»	LU 7.2 «ML60X»	465213.270-82
Lift unit ver. 7.2 «PDAHL S3»	LU 7.2 «PDAHL S3»	465213.270-83
Lift unit ver. 7.2 «SCHINDLER SX»	LU 7.2 «SCHINDLER SX»	465213.270-84
Lift unit ver. 7.2 «ML50S»	LU 7.2 «ML50S»	465213.270-85
Lift unit ver. 7.2 «MP VIASERIE»	LU 7.2 «MP VIASERIE»	465213.270-86
Lift unit ver. 7.2 «MASHIBA»	LU 7.2 «MASHIBA»	465213.270-87
Lift unit ver. 7.2 «HYUNDAI CAN»	LU 7.2 «HYUNDAI CAN»	465213.270-88
Lift unit ver. 7.2 «IMEM»	LU 7.2 «IMEM»	465213.270-89
Lift unit ver. 7.2 «BST»	LU 7.2 «BST»	465213.270-90
Lift unit ver. 7.2 «HIDRAL»	LU 7.2 «HIDRAL»	465213.270-91
Lift unit ver. 7.2 «MITSUBISHI»	LU 7.2 «MITSUBISHI»	465213.270-92
Lift unit ver. 7.2 «EASY TRONIC»	LU 7.2 «EASY TRONIC»	465213.270-93
Lift unit ver. 7.2 «GILAN»	LU 7.2 «GILAN»	465213.270-94
Lift unit ver. 7.2 «MGN»	LU 7.2 «MGN»	465213.270-95
Lift unit ver. 7.2 «GMV»	LU 7.2 «GMV»	465213.270-96
Lift unit ver. 7.2 «MLK»	LU 7.2 «MLK»	465213.270-97
Lift unit ver. 7.2 «TRAVIS»	LU 7.2 «TRAVIS»	465213.270-98
Lift unit ver. 7.2 «PCKЛ»	LU 7.2 «PCKЛ»	465213.270-99

Name	Short name	Designation
Lift unit ver. 7.2 «DIGILIFT»	LU 7.2 «DIGILIFT»	465213.270-100
Lift unit ver. 7.2 «KONE ESC»	LU 7.2 «KONE ESC»	465213.270-101
Lift unit ver. 7.2 «DMG CAN»	LU 7.2 «DMG CAN»	465213.270-102
Lift unit ver. 7.2 «KRONA»	LU 7.2 «KRONA»	465213.270-103
Lift unit ver. 7.2 «ORONA ARCA3»	LU 7.2 «ORONA ARCA»	465213.270-104
Lift unit ver. 7.2 «HD ONE»	LU 7.2 «HD ONE»	465213.270-105
Lift unit ver. 7.2 «INVT»	LU 7.2 «INVT»	465213.270-106
Lift unit ver. 7.2 «GPS»	LU 7.2 «GPS»	465213.270-107
Lift unit ver. 7.2 «QI TOUCH»	LU 7.2 «QI TOUCH»	465213.270-108
Lift unit ver. 7.2 «CMAPT»	LU 7.2 «CMAPT»	465213.270-109
Lift unit ver. 7.2 «MS 68»	LU 7.2 «MS 68»	465213.270-110
Lift unit ver. 7.2 «HIDRA CRONO»	LU 7.2 «HIDRA CRONO»	465213.270-111
Lift unit ver. 7.2 «MC 3000»	LU 7.2 «MC 3000»	465213.270-112
Lift unit ver. 7.2 «VIMEC E10»	LU 7.2 «VIMEC E10»	465213.270-113
Lift unit ver. 7.2 «MLC01»	LU 7.2 «MLC01»	465213.270-114
Lift unit ver. 7.2 «CPU100»	LU 7.2 «CPU100»	465213.270-115
Lift unit ver. 7.2 «THYSSEN GEC»	LU 7.2 «THYSSEN GEC»	465213.270-116
Lift unit ver. 7.2 «K-Type ESC»	LU 7.2 «K-Type ESC»	465213.270-117
Lift unit ver. 7.2 «BR100»	LU 7.2 «BR100»	465213.270-118
Lift unit ver. 7.2 «PLK»	LU 7.2 «PLK»	465213.270-119
Lift unit ver. 7.2 «MODEUS»	LU 7.2 «MODEUS»	465213.270-120
Lift unit ver. 7.2 «GUANGRI»	LU 7.2 «GUANGRI»	465213.270-121
Lift unit ver. 7.2 «KONE KCE»	LU 7.2 «KONE KCE»	465213.270-122
Lift unit ver. 7.2 «IFE»	LU 7.2 «IFE»	465213.270-123
Lift unit ver. 7.2 «EAGLE»	LU 7.2 «EAGLE»	465213.270-124

LU 7.2 is used with serially manufactured lifts of the following types:

«R»: in conjunction with RSA with lifts having no serial port, with automatic door;

«OTIS»: with OTIS lifts equipped with LCB-I (MCS-310, 320), LCB-II (MCS-220), LB-II (MCS-300), RCB-II (MCS-311, 321, 411, 413, 421), TCB\HCB (OTIS2000, GeN2), TCBC (GeN2 Can), GECB-II (MCS-222) control systems, as well as with the escalators and travolators of NCE, NCT, NPE (ECB, ECBII);

- «SHULK-17»: with SHULK lifts equipped with PKL-17 control system;
- «SHULK-32»: with SHULK, SHULM, SHULR lifts equipped with PKL-32 control system;
- «UKL/UL»: with lifts equipped with UKL (MPU control board), UL (PU-2, PU-3 control boards) and UEL (CPU main controller board) control system;
- «NKU-MPPL»: with NKU-MPPL lifts equipped with BPSH-1 control system (KDS-1, KDS-2 control boards);
- «UUL»: with RSUL (distributed control system) and UUL control unit;
- «SODIMAS»: with SODIMAS lifts equipped with NG12 control system;
- «SUL»: with SUL1 lifts manufactured by OAO «MEL» (JSC);
- «LG»: with LG lifts equipped with DI-1, DI-2 and DSS control system;
- «ESK»: with escalators (excluding OTIS);
- «AXEL»: with AXEL lifts equipped with ELE2000 control system (MRV1 control board);
- «ELEX»: with ELEX lifts (LEXQ3 control board);
- «THYSSEN»: with THYSSEN lifts (TCI, TCM, E-COR control boards);

- «SPUL»: with SPUL lifts (manufactured by ZAO «ETLI»);
- «OLYMPUS»: with OLYMPUS lifts;
- «KLEEMANN»: with KLEEMANN lifts (LiSA control boards);
- «DOPPLER»: with DOPPLER lifts equipped with E-Type control system (manufactured by SEC);
- «BLT»: with BLT lifts (MPK708 controller);
- «EXPRESS»: with EXPRESS lifts equipped with STEP control system (F5021 and SM-01-DP/C control boards);
- «THYSSEN TAC50»: with THYSSEN lifts (TAC-50 16Bit, 32Bit control boards);
- «SCHINDLER»: with SCHINDLER lifts (BIONIC 5, MICONIC BX, MICONIC MX control boards);
- «BG-15»: with lifts equipped with BG-15 control boards;
- «ORONA»: with ORONA lifts equipped with ARCA II control board;
- «NKU-MPPL BPSH-2»: with NKU-MPPL lifts equipped with BPSH-2, LIRA control boards;
- «ARKEL»: with lifts equipped with ARL-300, ARL-500, ARCODE control boards;
- «SODIMAS QI»: with lifts SODIMAS equipped with QI control board family;
- «TP»:
- «ORONA ARCA1»: with ORONA lifts equipped with ARCA 1 control board;
- «DMG»: with «DMG» lifts equipped with PLAYBOARD interface card;
- «MIK-EL»: with MIK-EL lifts equipped with MIKRONIK S-HI control board;
- «KONE»: with KONE lifts equipped with LCECPUnc, LCECPU40 and LCECPU561 control boards;
- «VEGA»: with VEGA, Liftex lifts having VEG2000 control board;
- «HYUNDAI»: with HYUNDAI lifts equipped with STVF7 control board;
- «NICE»: with lifts equipped with NICE3000 control board;
- «S9»: with lifts equipped with S9 control board;
- «AC-01»: with lifts equipped with AC-01 control board;
- «iAStar»: with lifts equipped with iAStar, AS380 control board;
- «FST2»: with lifts equipped with FST2 control board;
- «CANNY»: with lifts equipped with FR2000-STB-V9 and BL2000 control boards;
- «SILVER»: with lifts equipped with NETIS control board;
- «DOPPLER ACT»: with lifts equipped with ACT, ACH (AYBEY) control boards;
- «INV»: with platforms for persons with disabilities;
- «E9»: with UNGERT lifts equipped with E9 controller;
- «ECLIPSE»: with lifts equipped with SICON-4000 control board;
- «VASSLER»: with lifts equipped with VASSLER control board;
- «TMS600»: with KONE lifts equipped with TMS600 control board;
- «BETACONTROL»: with lifts equipped with KKWEBMON control board;
- «CARLOS SILVA»: with lifts equipped with HIDRA control board;
- «SHK6000»: with lifts equipped with SHK6000 control system;
- «TKL»: with lifts equipped with TKL control board;
- «SOYUZ»: with lifts equipped with SOYUZ control board;
- «LLC»: with KLEEMANN lifts equipped with LLC 100 control board;
- «SHL-R»: with lifts equipped with SHL-R (manufactured by ZAO SP «Pod'yom») control board;
- «FT9x0»: with THYSSEN escalators equipped with FT 9x0 control board;
- «VEK»: with VEK lifts equipped with SUL2010 (manufactured by OOP TsNTU «VEK») control board;
- «KOLLMORGEN»: with lifts equipped with MPK400 control board;
- «THYSSEN CMC»: with THYSSEN lifts equipped with CMC3, CMC4, CMC4+ control boards;
- «SECURLIFT»: with lifts equipped with SECURLIFT control board;
- «THYSSEN MCI»: with THYSSEN lifts equipped with MCI control board;
- «WIPO»: with lifts equipped with WP-CAN 3000 control board;
- «KLST»: with VESTNER lifts equipped with KLST control board;
- «ELCO MICRO»: with lifts equipped with ELCO MICRO control board;
- «KOYO»: with KOYO lifts equipped with KOYO control board;
- «BL6»: with SANHEY lifts equipped with BL6 control board;
- «WEBER»: with WEBER lifts equipped with WECON control board;
- «DAESUNG»: with HANDOK, YUNJIN and other lifts equipped with DAESUNG KJ-D100 control board;
- «GTE»: with lifts equipped with GTE control board;

- «ML65X»: with lifts equipped with ML65X control board;
- «SKG»: with SKG lifts;
- «ISL»: with lifts equipped with ISL control board;
- «ML60X»: with lifts equipped with ML60X control board;
- «PDAHL S3»: with lifts equipped with PDAHL S3 control board;
- «SCHINDLER SX»: with SCHINDLER SX lifts;
- «ML50S»: with lifts equipped with ML50S control board;
- «MP VIASERIE»: with lifts equipped with MP VIASERIE control board;
- «MASHIBA»: with lifts equipped with VS400-M control board;
- «HYUNDAI CAN»: with lifts equipped with STVF-7, WBVF and LE control boards;
- «IMEM»: with lifts equipped with SISTEL control board;
- «BST»: with lifts equipped with B08 control board;
- «HIDRAL»: with lifts equipped CP2 MC control board of version MAP-17;
- «MITSUBISHI»: with lifts equipped with HOPE-II, LEHY-II and LEHY-III control boards;
- «EASY TRONIC»: with lifts equipped with AXEL EASYTRONIC control board;
- «GILAN»: with lifts equipped with «GILAN» control board;
- «MGN»: a set for elevators meant for restricted mobility passengers;
- «GMV»: with lifts equipped with NEOS 10 and NEOS10+ control boards;
- «MLK»: with lifts equipped with MLK control board (manufactured by Mogilevliftmash);
- «TRAVIS»: with lifts equipped with «TRAVIS» control board;
- «PCKП»: with lifts equipped with MPU-2 (manufactured by KMZ);
- «DIGILIFT»: with lifts equipped with «DIGILIFT» control board;
- «KONE ESC»: with escalators KONE equipped with EMB501 control board;
- «DMG CAN»: with «DMG» lifts with CAN bus (without PLAYBOARD interface card);
- «KRONA»: with lifts equipped with KRONA control board;
- «ORONA ARCA3»: with ORONA lifts equipped with ARCA 3 control board;
- «HD ONE»: with lifts equipped with HD ONE control board (manufactured by HEDEFSAN);
- «INVT»: with lifts equipped with E100, E160 and E300 control boards;
- «GPS»: with «MITSUBISHI» lifts equipped with GPS 3 control board;
- «QI TOUCH»: with SODIMAS lifts equipped with QI TOUCH control board;
- «CMAPT»: with lifts equipped with «SMART CONTROLLER» (manufactured by ООО «NEIRON»);
- «MS 68»: with «MASHIBA» lifts equipped with MS 68 control board;
- «HIDRA CRONO»: with Carlos Silva lifts equipped with HIDRA CRONO control board;
- «MC3000»: with Haushahn lifts equipped with MC3000 control board;
- «VIMEC E10»: with lifting platform equipped with «VIMEC E10» control board;
- «MLC01»: with ISLv5 lifts equipped with MLC01 control board;
- «CPU100»: with lifts equipped with CPU100 control board;
- «THYSSEN GEC»: with THYSSEN escalators equipped with GEC control board;
- «K-Type ESC»: with MITSUBISHI escalators equipped with K-Type control board.
- «BR100»: with MOVILIFT lifts equipped with BR100 control board.
- «PLK»: lifts with programmable logic control board.
- «MODEUN»: with MODEUN lifts equipped with MD-G100 control board.
- «GUANGRI»: with GUANGRI lifts equipped with FIELU1 control board.
- «IFE»: with lifts equipped with IFE control board.
- «EAGLE»: with lifts equipped with EAGLE control board.

Lift unit operating conditions:

- Ambient air temperature: +1 to +40°C;
- Relative humidity (upper limit) 80% at +25°C;
- Atmospheric pressure (upper limit) 106,7kPa (800 mm Hg);
- Power supply voltage 230V ±10%, frequency 50±1 Hz.

Specification

Power supply of the LU is an external stabilized DC power supply, output voltage range is of 9 ... 24 V. Power consumed is no more than 4 W (it is equipped with a 12V 2A power adaptor by manufacturer).

An operating schedule: continuous, round the clock

Overall dimension: not more than 150*110*31mm

Weight: not more than 1.2kg (Except for 465213.270-95)

Contact control module nominal output voltage: 220V

Contact control module nominal output current: up to 1A

Out of service input type: potential

Out of service input nominal voltage: 24V

Input/output types, its specification and possible usage options are shown in Table 2.

Table 2

Input	Output	Name	Specification	Usage option
USER 1	USER 1	Input/Output	Input-dry contact; Output-voltage +5V, max.current 170mA	User defined
USER 2	USER 2	Input/Output	Input-dry contact; Output-voltage +5V, max.current 170mA	User defined
USER 3	USER 3	Input/Output	Input-dry contact; Output-voltage +5V, max.current 500mA	User defined
USER 4	USER 4	Input/Output	Input-dry contact; Output-voltage +5V, max.current 200mA	User defined, GOS input
	OUT 1	Output OUT1	Output-voltage +5V, max.current 1200mA	Dispatcher control, voice alert control, emergency light control, GOS power supply

LU's input/output types and its possible wirings shown in Appendix C.

Changes to connecting for option 465213.270-10

For lifts without serial interface as well as for lifts having relay logic controller as additional adaptor (the Relay Station Adapter) should be used – 465213.161-01

Changes to connecting for option 465213.270-21

Connection to escalators with controller having no serial interface is performed via the RSA.

Changes to connecting for option 465213.270-53 and 465213.270-95

Connection to lifting platforms for disabled and handicapped passengers, with no serial interface available should be performed with the use of dry contact inputs.

Changes to connecting for option 465213.270-11 and 465213.270-14...465213.270-20, 465213.270-22...465213.270-94, 465213.270-96...465213.270-119

Connection to microprocessor control boards via serial interface.

The operation time of the lift unit 7.2 and Intercom unit 7.2 powered from built in accumulator batteries is not less than 1 hour.

LIFT UNIT FUNCTIONS

As a part of LMDS, the LU performs monitoring of a lift operation and provides:

- two-way voice communication between a dispatcher and a lift cabin, cabin roof, machine room, lift pit and landing platform; it also provides audio signaling when calling dispatcher;
- warning on landing door opening when a cabin is not at the leveling zone;
- warning on the machine room door opening or control cabinet door opening (in case of machine room-less lifts);
- warning on the lift safety chain changes;
- identification of incoming warnings (where from and what signal is received);
- incoming warnings identification;
- lift control station logging;
- discovering and logging faults and error messages of the lift;
- detecting machine room/control cabinet penetration;
- remote lift shutdown by command from dispatcher (optional);
- supporting voice devices located in the cabin, on the cabin roof, in the machine room, pit and on landing platforms;
- voice communication system self test;
- floor number arrival messaging;
- audio background (microSD card is required);
- voice announcement remote renewal;
- remote firmware updating.

Based on information received from a lift control board, a lift unit forms the following standard statuses:

- Lift is not powered (connection with control board is established);
- "STOP" button clamped;¹
- Safety chain short circuit;²
- Safety chain open;
- Cabin door opened;¹
- Multiple door reversing;
- Door drive fault;
- Dispatcher call;
- Unauthorized cabin movement;
- Main drive fault;
- Shaft penetration;³
- Out of service;
- Machine room penetration;
- Machine room open;
- Maintenance mode;
- Cabin between floors;
- Cabin door sensor fault;¹
- Lack of serial port communication;²
- Lift unit failure;
- Voltage at safely chain begin checkpoint;
- USER1 state;
- USER2 state;
- USER3 state;
- USER4 state;
- No mains power;
- Safety circuit AC voltage.²

Lift unit options 465213.270-11, 465213.270-14 ... 465213.270-20, 465213.270-22 ... 465213.270-94, 465213.270-96 ... 465213.270-119 makes it possible to generate additional statuses, based on the data received via serial interface.

¹ Not generated for LU LNGS.465213.270-10

² Status generated for LU LNGS.465213.270-10 only

³ In the presence of free normally open contacts of Door closed (Landing door) switches on the lift - only for the execution of the LNGS.465213.270-10 option or the presence of information in the serial channel of the lift control station.

DELIVERY SET

The LU completeness depends on the option, and shown in Appendix B.

LIFT UNIT DEVICE

There are few sockets can be found on the top cover of the LU 7.2:

- "USB" to connect the LU to PC/Laptop for making settings.



ATTENTION!
When LU is connected to a PC via MiniUSB-cable, CAN bus operation is terminated

- “Service key” (of DB9 type, female), to connect the Service key or Service tool.

The LU has got the following controls:

- “PWR” backlit button to provide lift control station to power UP/DOWN (activates electromagnetic contactor), the service key/service tool should be connected;
- “CALL” backlit button to call dispatcher from the machine room;
- “RST” button to restart Wi-Fi module (press and hold for less than 3 seconds), reset of Wi-Fi and Ethernet parameters to factory-default (press and hold for longer than 3 seconds), switching over from current firmware to initial firmware (press and hold for longer than 10 seconds).

Controls of voice devices:

- “CAR” backlit button to initiate a call and to trigger the direction of a call between a cabin and cabin roof;
- “PIT” backlit button to establish the communication with pit/lower landing platform;
- “RST” button to cancel calls.

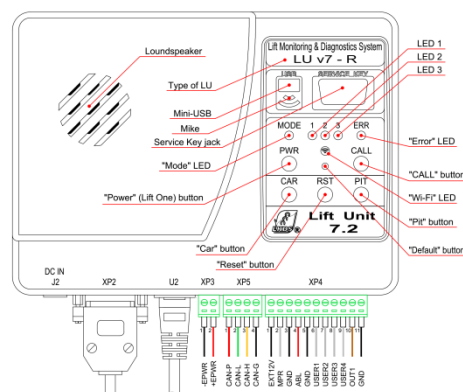

Fig.1 Lift unit 7.2 general view

The LU also has got the following indicators:

- “ERR” LED to indicate power supply failure by a series of flashes and to indicate data exchange via serial interface starts;
- “PWR” LED to indicate the LU power is ON;
- “1” LED indicates that both the interface board and the firmware is correct, Ethernet connection is also ready;
- “2” LED indicates data transmission via CAN, Wi-Fi and Ethernet;
- “3” LED indicates the current status of voice communication system and also indicates the presence of registered calls;
- “Wi-Fi” LED indicates operation status of Wi-Fi.

The purpose of indicators shown in Table 3.

Table 3

LED	Indication	Colour	Description
"1"	5 flashes per sec.	green	Interface board is not installed or memory fault
	1 flash per sec	green	Interface board is installed but no active firmware uploaded
	lit	green	Interface board is installed, active firmware is in use
	lit	red	Defective quartz resonator and LU is operated by the emergency source clock
	1flash per sec	red	Ethernet cable is not connected
	5 flashes per sec	red	Establishing DHCP or PPPoE connection
"2"	lit	green	Receiving data via Ethernet, CAN bus or Wi-Fi
	lit	red	Sending data via Ethernet, CAN bus or Wi-Fi
"3"	lit	green	Dispatcher call is registered
	5 flashes per sec	green	Network is not set up, LU configuring procedure is to be performed
	Not lit	-	Intercom is turned out
	Lit	red	Intercom with MR is turned on (call direction from lift to operator)
	flashing	red	Intercom with MR is turned on (call direction from operator to lift)
"ERR"	flash series	red	Error code that resulted in lift power off.
	flashing	Red	Service key is inserted or service tool is connected
	lit	Red	No data exchange via serial port
"PWR"	Lit	Red	Electromagnetic starter commanded to turn on
	Not lit		Electromagnetic starter commanded to turn off
"CAR"	Not lit	Blue	Intercom Unit is not accessible via CAN bus (or Wi-Fi)
	Flashing		Voice communication with cabin is active
	Lit		Intercom unit is accessible via CAN bus (or Wi-Fi), voice communication is not active
	flickering		Intercom unit accumulator battery is fault or absent
	flash series		Intercom unit is on battery power
"PIT"	Not lit	Blue	PIT Intercom Unit is not accessible via CAN bus (or Wi-Fi)
	Flashing		Voice communication with PIT is active
	Lit		PIT Intercom unit is accessible via CAN bus (or Wi-Fi), voice communication is not active
	Flickering		PIT Intercom unit accumulator battery is fault or absent
	Flash series		PIT Intercom unit is on battery power
"CALL"	Lit	Green	Voice call from MR is registered
	flashing		Voice communication between MR and operator is active

LED	Indication	Colour	Description
"Wi-Fi"	Not lit	-	Wi-Fi is turned off
	flashing continuously		Wi-Fi parameters are not set
«RESET»	Lit		Accumulator battery is fully discharged, no mains available
	flickering		Accumulator battery is not connected or damaged
For «- R» option (465213.270-10)			
"MODE"	Lit	Green	External door is closed, the voltage at safety chain begin checkpoint of RSA is present
	Not lit		One or more external door leafs is open
	flashing	Green	AC power at safety chain begin of RSA checkpoint
For all other options (excluding «- R»)			
"MODE"	Lit	Green	Lift Unit is on mains power
	flashing	Green	Lift Unit is on battery power

On the LU 7.2 housing base the following sockets are located:

- DC IN (J2): external power supply of 9...24V DC;
- XP2: Serial bus connector;
- U2: Ethernet LAN connector;
- XP3: Contactor control module socket;
- XP5: CAN bus for connecting additional devices;
- XP4: socket to connect GOS, MR door sensor, "USER1...USER4" inputs, "OUT1" output and battery connection jumper.

The LU's sockets in details are shown in Table 4.

Table 4

Socket	Pin No.	Marked as	Description
DC IN (J2)	1	DC IN	Lift unit power supply 9...24V DC
	2	GND	
XP2	1-9		Depends on lift unit option
U2	1-8		According to Ethernet standard
XP3	1	-EPWR	Contactor control module GND
	2	+EPWR	Contactor control module signal
XP5	1	CAN-P	CAN power +9...24V
	2	CAN-L	CAN Low
	3	CAN-H	CAN High
	4	CAN-G	CAN GND
XP4	1	EXT 12V	Battery connection
	2	MPR	Machine room door sensor
	3	GND	Common
	4	OoS	Out of Service input
	5	GND	Common
	6	USER1	USER1 input/output
	7	USER2	USER2 input/output
	8	USER3	USER3 input/output
9	USER4	USER4 or GOS input	

	10	OUT1	OUT1 output or GOS power
	11	GND	Common

The rescue battery is installed to feed the LU with power at power loss.



ATTENTION!

To connect the rescue battery to the LU's internal circuit short circuit the pins 1 and 3 of XP4 socket.

THE RELAY STATION ADAPTOR

The Relay station adaptor is intended for use in conjunction with Lift unit of "-R" option in order to obtain primary information about the state of the main signals of the lift/elevator. It has galvanic isolated (opto-coupled) inputs.

On the top cover of the RSA the following indicators are to be found (see Fig. 2):

- "STATUS" LED (red/green): indicates the operation mode (manual/auto) of the RSA. The red colour of the Led is meant for lifts with manual door, the green colour is meant for lifts with automatic door;
- "1" LED: depending on lift door type the LED indicates: signal "door opening" for automatic door; the safety chain state "prior to door";
- "2" LED: depending on lift door type the LED indicates: signal "door closing" for automatic door; the safety chain state "after door";
- "3" LED: safety chain end checkpoint;
- "4" LED: signal "MOVE DOWN";
- "5" LED: signal "MOVE UP";
- "6" LED: safety chain begin checkpoint.

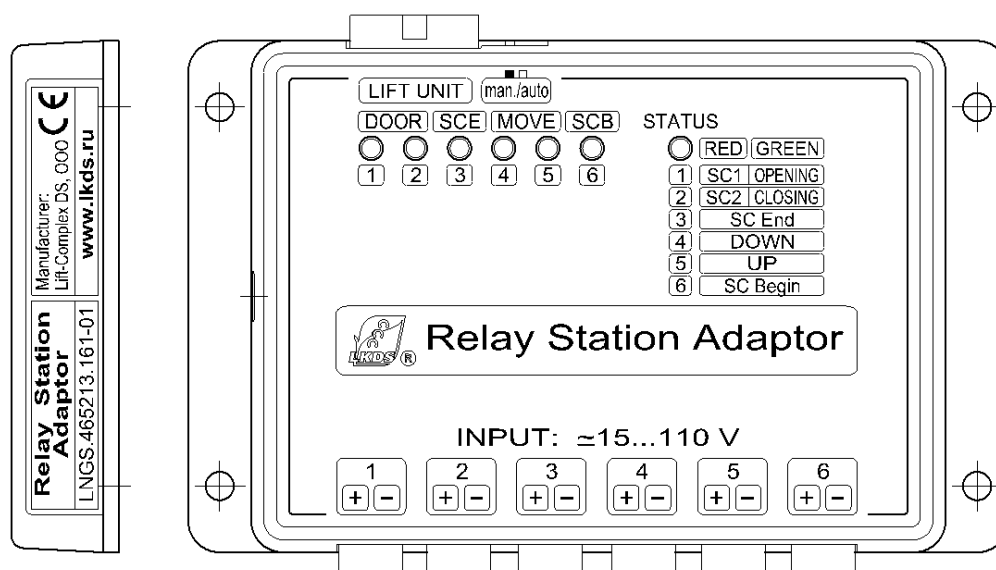

Fig.2 Relay Station Adaptor general view

From the right of the "LIFT UNIT" socket the switch "MAN/AUTO" is located. The switch must be set to the appropriate position depending of the door type used.

Appropriate checkpoints should be connected to the RSA through labeled connectors (see Fig.2) observing the polarity indicated on the sticker. Assumable input voltage is from 15 to 110V as indicated on the sticker.

DIAGNOSING FAULTS

The fault/error code is converted by the LU into corresponding status of the Lift Monitoring & Diagnostics System.

INTERCOM UNIT

The only control of the Intercom unit is the 'CALL' button that generates a request on establishing voice negotiation.

Pressing the "CALL" button and holding it for less than 1.5 sec will make a request for establishing voice communication with the lift unit location. To request communication with dispatcher the "Call" button must be pressed and hold for longer than 1.5 sec. In this case the voice notification "Your call has been registered, wait for an answer" follows.

Intercom unit 7.2 has got the following indicators:

- "MODE" LED indicates the operation mode and that the unit is on battery power;
- "Wi-Fi" LED indicates Wi-Fi communication is established;
- "CAN" LED indicates CAN bus communication established.

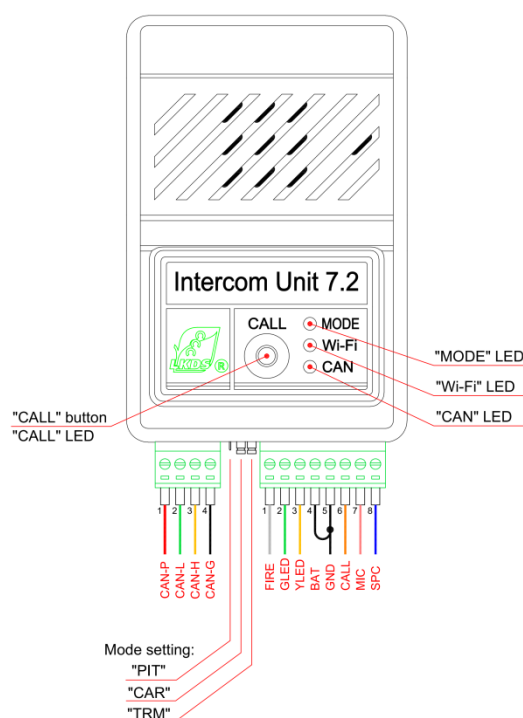

Fig.3 Intercom unit general view

Intercom unit 7.2 indicators and their modes are shown in Table 5.

Table 5

Name	Status	Colour	Designation
"MODE"	Flashing	Red	"PIT" mode. The unit is on battery power
	Flashing	Green	"CABIN" mode. The unit is on battery power
	Series of 2 flashes	Red	"PIT" mode. The unit is on CAN bus power
	Lit	Green	"CABIN" mode. The unit is on CAN bus power
"Wi-Fi"	Lit	Red	Data transfer via Wi-Fi
	Lit	Green	Connection with the LU via Wi-Fi established
	Dim	-	No connection with the LU via Wi-Fi
"CAN"	Lit	Red	Data transfer via CAN
	Lit	Green	Connection with the LU via CAN established
	Dim	-	No connection with the LU via CAN
"CALL"	Lit	White	Voice communication with dispatcher established
	Flashing	White	Voice communication with the LU established
	Series of 2 flashes	White	Dispatcher call registered
	Dim	-	Voice communication is OFF
	Flickering	White	Rescue battery fault or not wired

"Wi-Fi", "CAN"	Flashing both	Yellow	One more device with the same address present on CAN bus
-------------------	---------------	--------	--

There are two sockets and a jumper bar is present:

XP1 - meant for wiring input, triggering to Firemen transportation mode; for wiring LEDs of Yellow and Green to highlight pictograms, connecting external MIC and Speaker, wiring the CALL button and rescue battery jumper;

XP3 – CAN bus for connecting additional devices;

Jumpers: "PIT", "CABIN" and "TRM".

Pins of sockets are shown in Table 6.

Table 6

Socket	Pin No.	Label	Description
XP1	1	FIRE	Input of triggering to Firemen transportation mode
	2	GLED	Output to control green LED pictogram
	3	YLED	Output to control yellow pictogram
	4	BAT	Battery wiring
	5	GND	Common/Ground
	6	CALL	Call*
	7	MIC	Microphone input
	8	SPC	Loudspeaker output
XP3	1	CAN-P	Power supply +9...24V output
	2	CAN-L	CAN Low
	3	CAN-H	CAN High
	4	CAN-G	Common/Ground
Using with LU7.2-"Inv" (465213.270-53)**			
XP1	1	FIRE	USER1 input
	2	GLED	USER2 input
	3	YLED	USER3 input

*- Normally closed contact can also be used for both "CALL" button and "FIRE" input.

** - Pins shown also can be used as USER inputs being connected to the LU 7.2 "INV" option, operating in parallel with the corresponding inputs of the LU. Basic function (managing LEDs) is not locked by software.

LANDING INTERCOM (CAN BUS), SURFACE MOUNTED

The "CALL" button of the landing intercom device generates a request for establishing voice communication with dispatcher. Confirmation of the request is the audio notification: "Your call has been registered, wait for an answer".

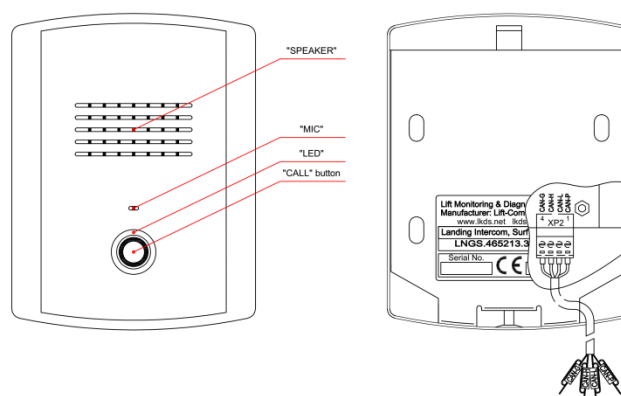

Fig.4 Landing intercom general view

XP2 connector is meant to connect the landing intercom to CAN bus. Possible indication of the backlit "CALL" button is shown in Table 7.

Table 7

Name	Status	Colour	Description
LED inside the "CALL" button	Lit	Green	CAN bus connection established
	Lit	Red	"CALL" button pressed
	Flashing	Green/red	A request for establishing voice communication has registered
	Flashing	Green	Voice communication is ON
	Flashing	Green/red	No data transfer between the LU and CAN bus
	Flashing	Yellow	CAN bus address conflict

Connecting more than 3 landing intercoms to CAN bus requires power supply unit of 24V DC, 2A(min) as output to power the LU.

LIFT UNIT AND INTERCOM DEVICES OPERATION

A Lift unit is to be connected to the Internet to transmit data to a monitoring center (call center). Either LAN connection of 10BASE-T/100BASE-T standard or wireless connection via Wi-Fi standard 802.11 b/g/n may be used. Both connection types can be used simultaneously(see Fig. 5).

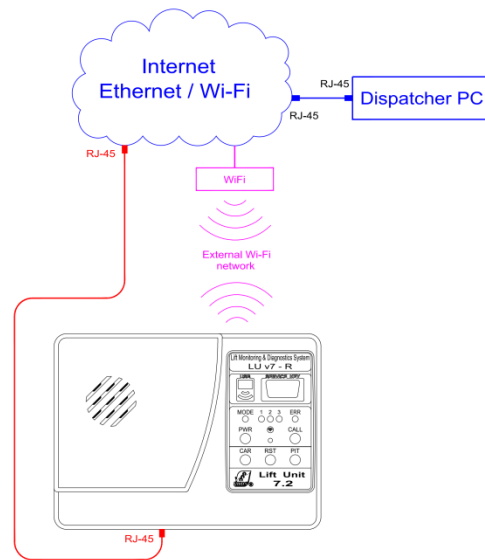

Fig.5 Internet connection example

An internal network generated by the LU 7.2 is used for connecting peripherals. This network can be supported by using CAN bus, internal wired interface or Wi-Fi (see Fig. 6).

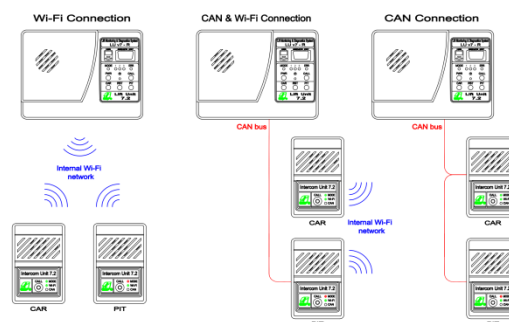

Fig.6 An example of internal network

A Lift unit CAN bus

The physical layer of the bus is a four-wire line. Two bus conductors (CAN-P and CAN-G) are used to power the devices, the rest are used as a two-wire differential line (CAN-L and CAN-H) using ISO-11898 transceiver. The total

length of the CAN bus of the lift unit 7.2 can be up to 350 m. Topology is a bus allowing to connect branches in 10-15 meters. Max number of devices can be connected is 64. On necessity to increase CAN bus length, a CAN bridge extender should be used. To ensure non-volatility of devices connected to the CAN bus and not having a built-in battery, a non-volatile power supply must be used instead of a network adapter.

To coordinate the load on the CAN bus on the end devices, you must connect the 120 Ohm resistor with special jumpers.

Wi-Fi interface

The Lift Unit 7.2 has got a built-in Wi-Fi module (standard 802.11 b / g / n), which can be used for connecting to the Internet using a wireless Wi-Fi connection (as an alternative to a LAN Internet connection). Additionally, the Wi-Fi module can work as an access point for creating an internal network. The internal network is designed to connect intercom units 7.2 via a Wi-Fi network. The identifier (SSID) of the internal Wi-Fi network is set by the manufacturer and does not change. When configuring the internal Wi-Fi network, you must specify both the network password and the channel number.

Intercom unit connectivity

The Intercom unit can be connected via CAN bus or Wi-Fi.

To work on the CAN bus the 4-wired connection should be made (CAN-P, CAN-L, CAN-H, CAN-G).

To balance the load on the CAN bus, bus terminators of 120Ohm resistor need to be connected. "Terminator" is connected using a special jumper "TRM" only on those device that is located at the ends of the CAN bus.

On necessity of using intercom units 7.2 connected via Wi-Fi, each Intercom unit must be prewired to the configured LU via CAN bus, for training and "binding".

A cable like shown on Fig.7 can be used for the purpose.

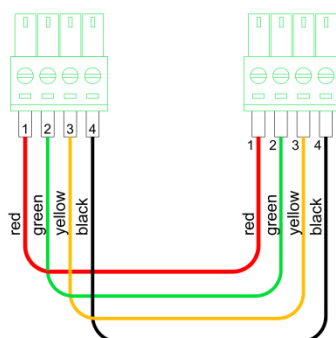

Fig.7 CAN cable example

When the training and binding process is over the "Wi-Fi" LED on Intercom unit starts lighting green.



ATTENTION!

The procedure of training and binding should be performed on each Intercom unit connected to the LU each time the Wi-Fi password changes.

Landing intercom connectivity

Connecting of the landing intercom is performed via CAN bus. Maximum number of devices should not exceed 64.

Prior to connecting the landing intercom device it's address on CAN bus must be set in range from 1 to 64.

To work on the CAN bus the 4-wired connection should be made (CAN-P, CAN-L, CAN-H, CAN-G).

To balance the load on the CAN bus, bus terminators of 120Ohm resistor need to be connected. "Terminator" is connected using a special DIP-switch only to device located at the ends of the CAN bus.

Intercom module

The intercom module of the LU 7.2 is designed to provide a voice negotiation between a lift cabin and a dispatcher

Intercom module is installed in a cabin behind the COP and is connected to the Intercom unit 7.2, installed on the roof of a cabin.



Exchange data with lift control station

The performance of the LU is provided by the microcontroller and the LU firmware. The LU is continuously communicating with a lift controller. Depending on the status of the controller, the LU's firmware generates a message on the current state of a lift, which is then sent over the Internet networks to be displayed on the monitoring devices (PC, mobile device). The list of statuses generated by the lift unit, their attributes, time intervals are given in Appendix A.

The set attribute of enabling the lift to be turned off upon detection of emergency state allows the LU to turn off the lift on detection of a corresponding state.

Exchanging data with the RSA

The relay station adapter polls the elevator control points and transmits information about the operation of the lift to the LU. The LU generates a message on the current state of the lift, which is then sent over the Internet to be displayed on

the monitoring devices. The list of statuses generated by the lift unit, their attributes, time intervals are given in Appendix A.

Machine room penetration control

A door sensor is used to check safety of the MR. When MR door is closed, the contacts of the sensor are closed as well. On opening door (the contacts are open) the alarm message with the audio is sent to the monitoring devices.

The LU nonvolatile memory (EEPROM)

Each LU has got nonvolatile memory (EEPROM) installed. The presence of EEPROM allows overriding of the firmware standard parameter table in the EEPROM, thus, changing the LU operation. A service tool should be used for the matter (see "Service tool operating manual").

The firmware update

The LU has the feature of the firmware remote updating, of the voice codec and Wi-Fi module updating.

The LU contains one constant and seven variable memory pages, that allow to store up to eight firmware. Remote reprogramming capabilities allow changing the contents of the seven pages of the chip's memory.

During LU's operation, only one of seven memory pages can be active. The bootloader and running firmware are active.

When the LU is delivered, the first memory page (bootloader) is set active by manufacturer.

The LU firmware is updated using the MProg utility (see the MProg utility user manual). Remote reprogramming is possible only from a personal computer.

The archive of firmware versions is located on site www.lmdsystem.com.

After firmware update, it is necessary to perform a function test in accordance with section 3 of the manual.

The manufacturer recommends update the LU firmware periodically.

Managing OUT1 output

The mode of operation of the OUT1 output is stored in EEPROM of a lift unit as per Table 3 of Appendix A. By default: 0-under dispatcher control (excluding for 465213.270-10 option).

Processing USER1...4 input/output

Inputs USER1..4 of the LU 7.2 can be mapped onto one of the existing states of the LU. By default, USER1..4 inputs are mapped onto "USER1..4 State", respectively. The mapping of USER1..4 inputs is also performed onto those states whose formation is prohibited. If mapping of several USER inputs is specified for the same state of the LU, then the resulting state value will be a logical "OR" of USER inputs.

The value "0" prohibits mapping of the USER input onto the state, the values "1..48" allow mapping the USER input onto the corresponding state "1..48", values "101..148" allow inverse mapping of the USER input onto the corresponding state "1..48." The values "210..214" determine the operation mode of the USER1..4 outputs (see table. Appendix A).

Intercom unit YLED and GLED output setting

The Intercom unit outputs of YLED and GLED are designed to control LED indicators of yellow and green luminescence in a lift cabin as required by EN 81-28:2018 art.4.1.5 and EN81-70:2018 art. 5.4.2.5. The yellow light pictogram indicates that the emergency call is registered, and the green pictogram starts lighting at voice negotiation start (connection is established) (see Fig. 8).

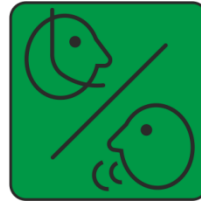

Fig.8 Yellow and Green pictograms

The yellow icon lights up when call button is pressed. The green pictogram lights up when the dispatcher's communication connection with a lift cabin is switched to on.

The outputs YLED, GLED are of 5V voltage with a current limit of 25 mA.



ATTENTION!

If a link between the IU and the LU or the control center/server is broken, the pictograms are alternately lit with a period of 2 seconds.

Voice communication tract self test

The function of automatic test of the voice communication tract has been implemented. The test is performed permanently. Had the link with the Intercom unit had broken, the message "Voice communication tract unavailable" should be generated by monitoring software.

To allow testing at address 11 of EEPROM, the value of minimum permissible quality of the route should be set, in percents (the range is from 0 to 99). The default value is 0. When set to 255, the automatic test is disabled.

Statuses "No mains power" and "Safety circuit AC voltage"

The status "No mains power" is formed when the LU switches to backup power from the battery when the mains voltage of 230V is out.

The status "Safety circuit AC voltage" is generated when there is an alternate component at checkpoint 110V (SCB) of the RSA. This state is formed only on LB 7.2 – P.

Passenger in a cabin control

For the LU of -R option, an algorithm for determining the presence of a passenger in a lift cabin is implemented. For LUs communicating with a lift controller via a serial bus, the status mentioned is used to indicate the presence of a person in a lift cabin (if such information is given out by a controller). The function is activated by writing the value "1" at the address 92 EEPROM of the LU.

Relay lift call circuit testing

The LU of –R option has got a function of monitoring the health of the call chain. To implement the call circuit test function on the relay lifts, it is necessary to connect the LU checkpoint "Out of Service" to the lift circuit and enable the call circuit health monitoring function by writing the value "99" at address 12 of EEPROM of the LU.

Audio in a cabin

The LU has an audible warning function in a lift cabin. Sounds in a lift cabin can be implemented in the form of: a sound signal, the phrase "The call has been registered. Wait for an answer", a floor arrival message, as well as playing back a soundtrack. The function becomes available on setting the values "0 ... 15" at the address 14 of EEPROM of the LU. The table of possible values is given in Appendix D.

Audio content from SD card

Playing back soundtracks in a lift cabin function is available when a microSD card is installed in Intercom Unit. WAV and MP3 formats are supported.

Governor overspeed sensor

To use the GOS it must be connected in accordance with the diagram shown in fig. 9. To enable receiving signals from the sensor the value "1" must be set at address 94 of EEPROM. Thus, the USER4 input/output is assigned an input for receiving data from the CSMA pin of the sensor, while the output OUT1 provides power to the sensor. In this case any previously assigned use of USER4 input/output and output OUT1 at addresses 3 and 9 of the EEPROM, is ignored.

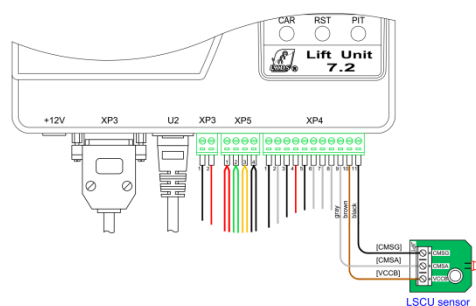

Fig.9 Governor overspeed sensor wiring

Contactor control module

Connecting the electromagnetic contactor to the LU is performed through the contactor control module (see. Fig. 10). The LED of the contactor control module provides indication of the on or off mode of the contactor.

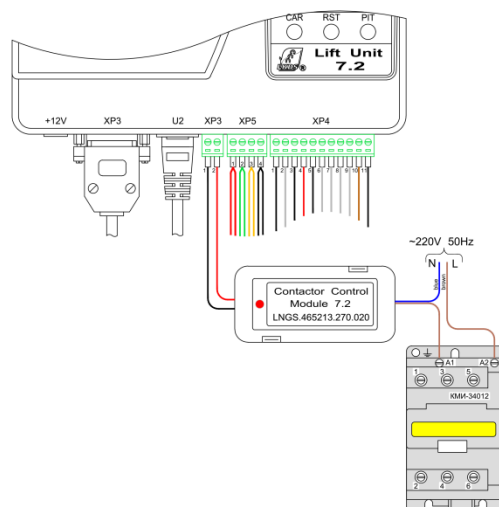

Fig.10 Contactor control module wiring

“Dispatcher call” filtering

For the LU, it is possible to enable the hardware filtering of “Dispatcher's calls”. To enable hardware filtering on the USER1..4 input, it is necessary to set the value “200” at the address 6..9, respectively. Triggering the USER1..4 input will result in blocking the formation of the “dispatcher's call” state.

USE OF A LIFT UNIT

Lift unit operation

Turning a lift ON



ATTENTION!

Before switching power to ON, make sure it is in proper health and there is no people in a shaft.

To switch lift power ON:

Insert a service key into the “SERVICE KEY” socket and make sure it is adopted (“ERR” led starts flashing);

- Press and hold “PWR” button until the actuator is engaged;
- Release “PWR” button;
- Remove the service key from socket.

Turning a lift OFF

Turning a lift OFF can be made either by LU automatically after receiving status with attribute permitting switching lift off set up or by dispatcher command via PC (see MPultPro manual).

It also can be made manually. To do so:

- Insert a service key into “SERVICE KEY” socket and make sure it is adopted (“ERR” LED starts flashing);
- Press and hold “PWR” button until actuator is engaged;
- Release “PWR” button;
- Remove the service key from the socket.

Using voice communication system to make a call to dispatcher

Voice negotiation from machine room

To initiate a voice negotiation it is necessary to press and hold lift unit “CALL” button for not less than 1.5 seconds and wait for voice confirmation of ‘Call has been registered. Wait for an answer’. Green LED lit means the request has been registered. Pressing ‘RST’ button will cancel the request for communication from the machine room. After answering a call by dispatcher a green ‘CALL’ LED starts flashing.

Voice negotiation from lift cabin/top of the cabin

To initiate a voice negotiation it is necessary to press and hold ‘CALL’ button on the lift cabin panel for not less than 1.5 seconds and wait for voice confirmation of ‘Call has been registered. Wait for an answer’.

To initiate a voice negotiation from top of lift cabin it is necessary to press and hold ‘CALL’ button on Intercom Unit for not less than 1.5 seconds and wait for voice confirmation of ‘Call has been registered. Wait for an answer’.

Using voice intercom communication

Voice communication with pit or lowest landing

To initiate an intercom negotiation it is necessary to press and hold ‘CALL’ button on Intercom Unit in pit/lowest landing for less than 1.5 seconds or press ‘PIT’ button on the LU. After connection is established the ‘Call’ button on

Intercom Unit will light continuously, and 'PIT' LED will be flashing on the LU. To change the direction of a call can be made by pressing 'PIT' button on the LU. Expiration time is set to 3 minutes.

Voice communication with lift cabin/top of lift cabin

To make a request for intercom communication it is necessary to press and hold 'CALL' button on Intercom Unit for less than 1.5 seconds or press 'CAR' button on the LU. After connection is established 'Call' button on Intercom Unit will be lit continuously, and 'CAR' LED start flashing on lift unit. Redirection of call is performed by pressing 'CAR' button on the LU. Expiration time is set to 3 minutes.

To terminate the intercom communication 'RST' button must be pressed on the LU.

Using voice communication system in firemen transportation mode (phase 2)

For triggering of negotiated communication to the mode of firemen transportation (FTM) it is necessary to activate the input "FIRE" on the intercom, installed in the PIT, or on the cabin roof. After the intercom goes into the FTM mode, the LED indicator of the CALL button of the intercom unit (located in PIT) will flash as well as the RST LED of the LU; a voice negotiation between the lift cabin and the landing intercom starts in the CABIN-PLATFORM direction. Pressing and holding CALL button on landing intercom reverses call direction (voice can be heard in the cabin).

Lift shutdown reason indication

Indication of faults leading to a lift shutdown is carried out by the "ERR" LED indicator located on the front panel of the lift unit. The fault is determined by counting the number of flashes of the "ERR" LED. The interval between bursts is four seconds. The correspondence between the error number and the number of indicator flashes is given in Appendix A.

When the power supply of the lift is cut off by the lift unit, the change in the state of the check points is recorded, it can be observed in the dispatch utility or using the service device (see Service tool operating manual).

Maintenance mode

When the service key is inserted into the "SERVICE KEY" socket, the lift unit switches to the maintenance mode.

The mode is intended for the maintenance of the lift by personnel. In this mode, the elevator unit does not cut off the power supply to the elevator upon detecting a condition leading to a lift shutdown.

After completing maintenance, the service key must be removed from the socket.

Safety precautions

Electric shock protection class rating corresponds to class III per IEC 61140.

Only person who have been trained in safety, as well as that who have studied this operating manual can be admitted to work with the LU.

During operation and maintenance, it is necessary to have in mind the high voltage (life-threatening) is inside the LU; therefore, LU operation with the cover removed is prohibited.

Connecting and disconnecting external circuits of the LU should be carried out with the lift input device powered OFF.

Battery maintenance

Battery installed in the LU has the limited life time (2-3 years). Exceeding this period as well as when receiving message "Battery fault" the battery must be replaced. Flickering "RST" led means battery fault or battery is absent.

Reset to factory defaults

To return to factory default settings use a thin tool (like a paperclip) to press and hold 'RST' button (see Figure 1), wait until LED start flashing and then release the button. Factory default settings are as follows: connection type – DHCP,

network key reset to www.lkds.ru, external Wi-Fi network settings are cleared. Configuring the LU becomes possible with the use of ConfigLBPro utility.

Battery wiring

The LU and Intercom devices are having the rescue batteries installed. To connect the battery of 18650 type and with capacity of 2000 mA/h to the LU circuit it is necessary to install jumper between terminals 1 and 3 of XP4 (XS4) jack, as shown on Fig.11. To connect the battery of 14500 type and with capacity of 750 mA/h to the intercom unit circuit it is necessary to install jumper between terminals 4 and 5 of XP1 (XS1) jack, as shown on Fig.12.

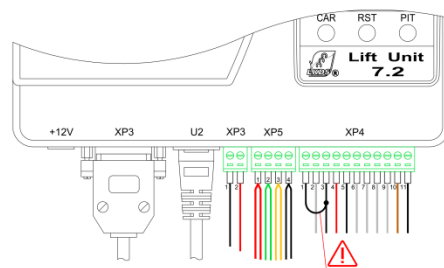

Fig.11 Battery wiring

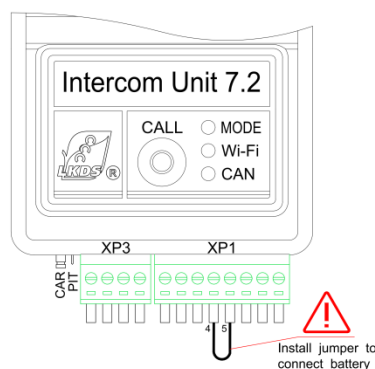

Fig.12 Intercom unit battery wiring

Setting the intercom unit mode

There are two modes –“Cabin” and “Pit – the Intercom Unit operates in. The mode is selected by jumper and is indicated by ‘MODE’ LED. Green LED shows ‘Cabin’ mode, red LED means ‘Pit’.

Triggering intercom unit into firemen transportation mode should be made as described in Intercom unit operational manual.

Specifying the "CALL" button contact type and intercom unit's "FIRE" input

Upon delivery, a normally open contact type is set for the "Call" button and the "FIRE" input. To change the type of contact to normally closed perform the following:

- press and hold the "Call" button on the intercom unit;
- close pins 6 and 5 of XP1 terminal of the intercom unit to set the normally closed type of the "Call" button of the lift cabin; close terminals 1 and 5 of the XP1 terminal to set the normally closed type of the state of the "FIRE" input of the intercom unit;
- supply power from the battery by connecting the XP1 terminal with jumper installed between the terminals 4 and 5;
- wait (more than 10 sec.) for flashing of the "MODE", "WI-FI", "CAN" LEDs in red-green color, then release the "Call" button on the intercom unit.

OPERATIONAL TESTING

After installation and commissioning of a lift unit it is recommended to perform its operational testing. Such testing must be performed also after reconstruction and periodically, not less frequent than once every 12 months. The testing procedure is as stated by RE 3434-001-49739805-07 manual.

Procedure for operational testing:

- Do what is listed in 'Action sequence' column of Table 8;
- Check registered statuses by monitoring and diagnostics system with those listed in 'What should be registered' column of Table 8.

Before starting each item of testing procedure, it is necessary to:

- Restore normal operating condition of electric diagram and equipment of lift or its initial status;
- Provide power supply to lift using service key;
- Reset all faults;
- Perform calibrating journey including door opening/closing.

Table 8

No	What to check. The sequence of actions	Expecting result
1	Checking dispatcher call audio and visual notification. Press 'Call' button in lift cabin.	After 'Call' button is pressed in lift cabin, audio and visual notification should be received in monitoring software.
2	Checking dispatcher call audio and visual notification from the MR. Press 'Call' button in the MR.	After 'Call' button is pressed in MR, audio and visual notification should be received in monitoring software.
3	Checking of two-way communication between dispatcher and lift cabin. Initiate a voice call with lift cabin from the dispatcher PC.	Make sure communication is available.
4	Checking of two-way communication between dispatcher and the MR. Initiate a voice call with the MR from PC.	Make sure communication is available.
5	Checking of intercom voice communication (repair communication) and voice communication in firemen transportation mode. Turn on intercom and try it using different modes.	Make sure communication is available.
6	Checking audio and visual notification on landing door opening with no lift cabin in landing zone. Open landing door with no lift cabin in landing zone.	When landing door is open the PC should register audio and visual notification. LU should shutdown a lift ³
7	Checking of audio and visual notification on opening machine room door. Open the machine room door.	Opening the MR door should be accompanied by audio and visual notification of monitoring PC.
8	GOS testing ¹ : - Switch lift into controlled from the MR mode; - Disconnect a lift from mains; - Disconnect 'GOS sensor' (CMSA) wire either from the LU or from sensor; - Power lift ON ; - Perform test journey.	After start of lift movement PC should register 'Main drive fault' status. The LU should shutdown the lift.
9	Control over unauthorized movement of lift cabin ¹ : - Switch lift into controlled from the MR mode; - Move lift cabin to any of stops in the middle of the shaft; - Wait about 4 seconds to exclude cabin inertia; - release brake lever.	After lift starts moving the PC should register 'Unauthorized cabin movement' status. LU should shutdown the lift.
10	Checking of audio and visual notification on safety chain open. Open safety chain.	When safety chain is open PC should register audio and visual notification safety chain is open.

11	Checking of lift location. Press 'Call' button in lift at specified address.	After 'Call' button is pressed in lift cabin PC should register audio and visual notification from specified lift.
----	--	--

Notes:

1. No test should be performed on a lift with a speed control device installed.
2. Powering OFF a lift off is to be performed only when the LU protection against the shaft penetration is used. When the lift has its own protection system, powering lift off by LU is no need to be tested.
3. Checking of intercom voice communication and voice communication in firemen transportation mode is performed only on necessity.

MAINTENANCE

General terms

Maintenance is carried out according to a preventive system, which provides quarterly maintenance.

Maintenance of equipment installed in a lift shaft is performed by an electrician.

Maintenance of equipment installed in the MR is carried out by electricians of dispatching equipment and teleautomatics.

Safety precautions

When carrying out work, the requirements of both safety and industrial instructions should be met.

Quarterly maintenance

Quarterly maintenance includes:

- external inspection of the product;
- cleaning LU and OGS, if any, of dust and dirt;
- checking of state of wiring, harnesses and terminals;
- checking and tightening of threaded connectors.

RUNNING REPAIR

During the warranty period, the repair of the LU is made by manufacturer.

Warranty period of the LU is 18 months from the date of commissioning, but not more than 24 months from the date of delivery to the consumer, provided that they comply with the rules for transportation, storage, installation and operation as specified in operating and installation manuals, instructions on usage, commissioning, fine-tuning and run-in.

Repair of the LU is carried out by the manufacturer or qualified personnel trained and certified at manufacturer's training center.

Repair of the LU must be performed in technical workshop by qualified personnel. Performing repair operations, it is necessary to comply with the requirements for protecting integrated microcircuit from static electricity.

STORAGE

The LU of the Lift Monitoring & Diagnostics System can be stored up to 6 months from the date of manufacturing.

The LU originally packed must be stored in enclosed spaces with natural ventilation, without artificial climate regulators, where the humidity and temperature fluctuation is less than in open air, located in moderate/cold climatic region.

Storage rooms must be free from dust, vapor of acids or alkali, aggressive gases and other harmful or corrosive substances.

TRANSPORTATION

Packed LU must be transported by closed transportation means (railway carriages, containers, closed trucks, etc.) of any way with the exception of naval transportation, in accordance with acting rules for transportation by this particular type of transportation.

When transporting by air, LU in original packing must be stored in heated pressurized compartments.

Placement and fixing of boxes must ensure their stable positioning, eliminating any possibility of their displacement and rough knocking onto each other and transportation vehicles walls. Allowed stacking – not more than 5 crates up.

In the course of transportation it is necessary to comply with notices on transportation crates.

Transportation and intermediate storage time should not exceed three months.

As concerns climatic impacts during transportation must be followed.

After transportation under negative temperatures or in excessive humidity LU's must be matured under normal climatic conditions for at least 24 hours before installation and commissioning.

APPENDIX A

Table 1 The LU 7.2 Status formation algorithm

No	Lift Unit State	State condition
1	Maintenance mode	Service key installed or service tool connected
2	Firmware restart	Lift Unit microprogram restart
3	Multiple door reversing	Multiple door opening-closing without cabin motion (number of reversals-address 4 of NVRAM)
4	Machine room penetration	Door sensor is open, service key not installed
5	Cabin door opening	Inner algorithm
6	Lift cabin movement detected	Inner algorithm
7	Cabin door starts opening	Inner algorithm
8	Landing door opening	Inner algorithm
9	Lift is not powered	No voltage at Safety Chain Begin check point
10	"STOP" button clamped	
11	Door opened	
12	Safety chain open	No voltage on Safety Chain End check point while Safety Chain Begin check point is powered
13	Door is not closed	No Door Closing signal after Door Opening signal
14	Safety chain short circuit	Simultaneous presence of UP/DOWN signals and Door Closing /Door Opening signals
15	Dispatcher call	Closing "CALL" and "Common/Ground" terminals
16	Unauthorized cabin movement	Impulses from OGS while impulses "UP"/"DOWN" are absent
17	Main drive fault	Cabin upward/downward motion while no impulses from OGS
18	Door drive fault	Continuous signal either of Door Opening or Door Closing
19	Shaft penetration	Door Closed without Up/Down signals, as well closing more than two Door Closed contacts
20	Safety device fault	Door locker's contact bounce
21	Out of service	Lift is switched to maintenance mode manually, no link with controller, or critical error from controller received
22	Machine room open	MR door sensor is open while service key is installed
23	Voltage at safety chain begin checkpoint	Voltage at Safety Chain Begin check point
24	Movement with safety chain open	Either of "UP"/"DOWN" impulses present while safety chain is open
25	Cabin between floors	No "Door opening" signal after "UP"/"DOWN" impulse completion (status can be cleared only after "UP"/"DOWN" signals appear)
26	Cabin door sensor malfunction	
27	Lack of serial port communication	No link with the Lift Controller or the RSA via serial interface
28	Main drive is ON	Either of "UP" or "DOWN" signals appear
29	User Bit	Signal on XP4 pin 4
30	Reserved	
31	Reserved	
32	Reserved	
-	Full stop of cabin by inertia	

-	Closing door relay response time	
-	'Lift on' button clamping time	
-	Door opening time	
-	Cabin door sensor ready	
-	Landing door sensor ready	
-	Machine room access permission	
-	Lift is switched on (see Note 3)	
33	USER1 state	Closing "USER1" and "Common/Ground" contacts
34	USER2 state	Closing "USER2" and "Common/Ground" contacts
35	USER3 state	Closing "USER3" and "Common/Ground" contacts
36	USER4 state	Closing "USER4" and "Common/Ground" contacts
37	No mains power	No mains power
38	Safety circuit AC voltage	The presence of an alternate component at Safety Chain Begin control point
39	Fire hazard	Signal obtained from lift controller or mapped of one of USER 1...4 inputs
40	Backup battery fault	

Table 2 Lift unit parameters

No.	LU State	Algorithm resolution bit address	Trigger states bit address	Lift power off enable bit address _(see Note 2)	Address of value of LU time intervals	Number of 'ERR' LED flashes on power
1	Maintenance mode	19	99	147	200	21
2	Firmware restart	20	100	148	201	22
3	Multiple doors reversing	21	101	149	202	23
4	Machine room penetration	22	102	150	203	24
5	Cabin door opening	23	103	151	204	25
6	Lift cabin movement detected	24	104	152	205	26
7	Cabin door starts opening	25	105	153	206	27
8	Landing door opening	26	106	154	207	28
9	Lift is not powered	27	107	155	208	29
10	'STOP' button clamped	28	108	156	209	30
11	Cabin door opened (see Note 4)	29	109	157	210	31
12	Safety chain open (see Note 5)	30	110	158	211	32
13	Door is not closed	31	111	159	212	1
14	Safety chain short circuit	32	112	160	213	2
15	Dispatcher call	33	113	161	214	3
16	Unauthorized cabin movement	34	114	162	215	4
17	Main drive fault	35	115	163	216	5
18	Door drive fault	36	116	164	217	6
19	shaft penetration	37	117	165	218	7
20	Safety Device fault	38	118	166	219	8
21	Out of service (see Note 1)	39	119	167	220	9
22	Machine room open	40	120	168	221	10
23	Voltage at safety chain begin checkpoint	41	121	169	222	11
24	Movement with safety chain open	42	122	170	223	12
25	Cabin between floors	43	123	171	224	13
26	Cabin door sensor malfunction	44	124	172	225	14
27	Lack of serial port communication	45	125	173	226	15
28	Main drive is on	46	126	174	227	16
29	User bit (see Note 1)	47	127	175	228	17
30	RESERVED	48	128	176	229	18

No.	LU State	Algorithm resolution bit address	Trigger states bit address	Lift power off enable bit address ^(see Note 2)	Address of value of LU time intervals	Number of 'ERR' LED flashes on power
31	RESERVED	49	129	177	230	19
32	RESERVED	50	130	178	231	20
-	Full stop of cabin by inertia	-	-	-	232	-
-	Closing door relay response time	-	-	-	233	-
-	'Lift on' button clamping time	-	-	-	234	-
-	Door opening time	-	-	-	235	-
-	Cabin door sensor ready	-	-	-	236	-
-	Shaft door sensor ready	-	-	-	237	-
-	Machine room access permission	-	-	-	238	-
-	Lift is switched on (see Note 3)	-	-	-	239	-
33	USER1 state	51	131	179	240	-
34	USER2 state	52	132	180	241	-
35	USER3 state	53	133	181	242	-
36	USER4 state	54	134	182	243	-
37	No mains power	55	135	183	244	-
38	Safety circuit AC voltage	56	136	184	245	-
39	Fire hazard	57	137	185	246	-
40	Backup battery fault	58	138	186	247	-

Notes:

The algorithms for processing the "Out of Service" and "User bit" states are mutually exclusive, since they use same input to the LU.

If a bit enabling turning off the lift (at addresses 147 ... 178) is set to "1", then it is automatically considered trigger, that is, it is considered that the corresponding bit at addresses 99 ... 130 is set to "1".

Time interval for the "Lift on" state value must be greater than the "Hold time of the lift button".

The timer for the "Cabin door opened" state has a seconds tick. The response time using the standard parameter table is 60 seconds.

The "Safety chain open" state timer of the "-P" version has a ten-seconds tick. Response time using standard parameter table is 5 minutes.

Table 3. Service codes

EEPROM address	Description	Possible values
3	OUT1 output mode	0- Dispatcher controlled (using "Output1" button); 1- used to control the voice annunciator; 2- cabin emergency lighting control; 3- power cutout control; 4- dispatcher controlled (using "Output2" button); 10-Smooth shutdown for 3 sec.; 11-call from 2nd floor (reserved); 12-triggering on "power on" command; 13- YLED is on; 14-GLED is on.
4	Number of door reversing	1...15
5	CAN POWER output mode	210- Dispatcher controlled (using "Output1" button); 211- used to control voice annunciator; 212- cabin emergency lighting control; 213- power cutout control; 214- dispatcher controlled (using "Output2" button); 220- Smooth shutdown for 3 sec.; 221- call from 2nd floor (reserved); 222- triggering on "power on" command; 223- YLED is on; 224-GLED is on
6	USER1 input/output mode	0- disables mapping of the USER input onto state or control point; 1...48- enables mapping of the USER input onto the corresponding 1...48 state; 101...148- enables inverse mapping of the USER input onto the corresponding 1...48 state; 51...98- enables mapping of the USER input onto the corresponding control point; 151...198- enables inverse mapping of the USER input onto the corresponding control point; 210- Dispatcher controlled (using "Output1" button); 211- used to control voice annunciator; 212- cabin emergency lighting control; 213- power cutout control; 214- dispatcher controlled (using "Output2" button); 220- Smooth shutdown for 3 sec.; 221- call from 2nd floor (reserved); 222- triggering on "power on" command; 223- YLED is on; 224-GLED is on
7	USER2 input/output mode	0- disables mapping of the USER input onto state or control point; 1...48- enables mapping of the USER input onto the corresponding 1...48 state; 101...148- enables inverse mapping of the USER input onto the corresponding 1...48 state; 51...98- enables mapping of the USER input onto the corresponding control point; 151...198- enables inverse mapping of the USER input onto the corresponding control point; 210- Dispatcher controlled (using "Output1" button); 211- used to control voice annunciator; 212- cabin emergency lighting control; 213- power cutout control; 214- dispatcher controlled (using "Output2" button); 220- Smooth shutdown for 3 sec.; 221- call from 2nd floor (reserved); 222- triggering on "power on" command; 223- YLED is on; 224-GLED is on
8	USER3 input/output mode	0- disables mapping of the USER input onto state or control point; 1...48- enables mapping of the USER input onto the corresponding 1...48 state; 101...148- enables inverse mapping of the USER input onto the corresponding 1...48 state; 51...98- enables mapping of the USER input onto the corresponding control point; 151...198- enables inverse mapping of the USER input onto the corresponding control point; 210- Dispatcher controlled (using "Output1" button); 211- used to control voice annunciator; 212- cabin emergency lighting control; 213- power cutout control; 214- dispatcher controlled (using "Output2" button); 220- Smooth shutdown for 3 sec.; 221- call from 2nd floor (reserved); 222- triggering on "power on" command; 223- YLED is on; 224-GLED is on
9	USER4 input/output mode	0- disables mapping of the USER input onto state or control point; 1...48- enables mapping of the USER input onto the corresponding 1...48 state; 101...148- enables inverse mapping of the USER input onto the corresponding 1...48 state; 51...98- enables mapping of the USER input onto the corresponding control point; 151...198- enables inverse mapping of the USER input onto the corresponding control point; 210- Dispatcher controlled (using "Output1" button); 211- used to control voice annunciator; 212- cabin emergency lighting control; 213- power cutout control; 214- dispatcher controlled (using "Output2" button); 220- Smooth shutdown for 3 sec.; 221- call from 2nd floor (reserved); 222- triggering on "power on" command; 223- YLED is on; 224-GLED is on

EEPROM address	Description	Possible values
10	Number of floors, equals to 0 for bridge scheme	1...31
11	Voice tract checkup is on	0- Voice tract checkup disabled; 1...99- the value of permissible quality of voice communication in percents (recommended value is 20)
12	Out of service input mapping	0,255- doesn't change mapping mode; 1...48- enables mapping out of service input onto the corresponding 1...48 state; 101...148- enables inverse mapping of out of service input onto the corresponding 1...48 state; 51...84- enables mapping out of service input onto the corresponding control point; 99- enables function of control of the calls circuit order; 151...184- enables inverse mapping out of service input onto the corresponding control point
13	Lift number in the group	
14	Sound notification in cabin	See Lift unit ver.7.2 Operational manual, Appendix D
18	EEPROM table usage enabled	0-standatd table; 85-EEPROM table
83	Turning on lift on request from the line enabled	0 – prohibited; 1 – allowed
84	Inverse bit	0 – door closed, contact open; 1 – door closed, contact closed
85	Out of service input inverse bit	1 – voltage present; 0 – no voltage
86	Turning on at lift power on	0=yes; 1=no
87	Cabin door penetration	0-not proceed; 1-proceed
91	Bit enabling additional messages formation	0-off; 1-on
92	Monitoring passenger in a cabin	0-disable; 1-enable
94	Overspeed governor sensor support	0- Disabled; 1- enabled. If Enabled, USER4 input/output is configured to exchange data with overspeed governor sensor output, where as output OUT1 assigned to supply power. This case all previously made assignments are ignored
95	Exchange speed rate for UKL/UL lift	0-4800; 1-6900 bps
96	Landing door indicator mode	0-safety device only; 1-standard
97	Main drive speed	0 – 0,35-0,8 mps; 1 -0,71-1,6 mps
98	Overspeed governor sensor type	0 – magnet; 1 - optical

Table 4. interval code correspondence to the real time

Interval code	Time in ticks	100 msec tick Time in seconds	One-second tick Time in seconds	10-second tick Time in seconds
0	0	0	0	0
1	3	0.3	3	30
2	4	0.4	4	40
3	5	0.5	5	50
4	6	0.6	6	60
5	10	1	10	100
6	15	1.5	15	150
7	20	2	20	200
8	30	3	30	300
9	40	4	40	400
10	60	6	60	600
11	80	8	80	800
12	100	10	100	1000
13	120	12	120	1200
14	160	16	160	1600
15	250	25	250	2500

Table 5 Mapping of USER1...USER4 and OUT1 onto the LU checkpoints

Value	Checkpoint name	Inverse value	Description
51	Lift powered	151	101
52	Prior to cabin "STOP" button	152	STP1
53	After cabin "STOP" button	153	STP2
54	Prior to cabin door checkpoint	154	CD1
55	After lift cabin door checkpoint	155	CD2
56	Safety chain end	156	RKD
57	Door opening relay	157	ROD
58	Door closing relay	158	RZD
59	Movement relay	159	RD
60	Out of service	160	ABL
61	Machine room door sensor	161	MPR
62	Cabin or machine room "CALL" button	162	CALL
63	Overspeed governor sensor impulses	163	CMSA
64	"Voice informant" connected		RIN
65	Lift "Power ON" button		PWR
66	Machine room "CALL" button	164	CMP
67	USER1 input	165	USER1
68	USER2 input	168	USER2
69	USER3 input	169	USER3
70	USER4 input	170	USER4
71	Reserved	171	-
72	Reserved	172	-
73	Mains power 220V	173	220V
74	OUT1 output state	174	OUT1
75	Reserved	175	-

Value	Checkpoint name	Inverse value	Description
76	Upward motion attribute	176	UP
77	Downward motion attribute	177	DOWN
78	15kg cabin load	178	15KG
79	90% of cabin load	179	90%
80	Overload (110% of load)	180	110%
81	Reserved	181	-
82	Door zone sensor	182	DTO
83	Landing door leaf open	183	UB1
84	Both landing door leafs open	184	UB2

Notes:

1. Should several inputs are assigned to the same checkpoint, so the resulting value for checkpoint state will be logical 'OR' for all inputs
2. Redefining of checkpoint is performed after main definition and unconditionally replaces status of man definition

APPENDIX B

Table 1. Complete set of LU ver. 7.2 depending on design version

		Lift Unit 7.2														
		-10	-11	-12	-14	-15	-16	-17	-18	-19	-20	-21	-22	-23	-24	-25
Name	Description	Quantity														
Lift unit	465213.270	1	1	1	1	1	1	1	1	1	1	1	1	1	1	1
Relay station adaptor	465213.161-01	1										1				
Governor overspeed sensor	465213.065	1														
Cable	465213.060.610-02	1														
Cable	465213.060.610(-01)		1		1		1		1	1		1	1			
Cable	465213.060.620			1												
Cable	465213.060.630					1										
Cable UUL	465213.060.630-01							1								
Cable LG-DSS	465213.060.640										1					
Cable ELEX	465213.060.920-02													1		
Cable SCHINDLER	465213.060.610-09														1	
Cable SPUL	465213.060.660															1
LG-DI adaptor	465213.060.271-02										1					
Power adaptor ~220B /+12B 2A		1	1	1	1	1	1	1	1	1	1	1	1	1	1	1
Terminal block	465213.270.050	1	1	1	1	1	1	1	1	1	1	1	1	1	1	1
Wiring Harness	465213.270.060	2	2	2	2	2	2	2	2	2	2	1	2	2	2	2
Screw	B.M3x20 DIN84	2	2	2	2	2	2	2	2	2	2	1	2	2	2	2
Cable	465213.161.200	1										1				
Door sensor	IO 102-2 (MC31)	1	1	1	1	1	1	1	1	1	1	1	1	1	1	1
Holder	465213.270.002-01	1	1	1	1	1	1	1	1	1	1		1	1	1	1
Buckle	CV-300	2	2	2	2	2	2	2	2	2	2		2	2	2	2
Holder	465213.270.002	1	1	1	1	1	1	1	1	1	1	1	1	1	1	1
Intercom unit 7.2	465213.270.500	1	1	1	1	1	1	1	1	1	1		1	1	1	1
Intercom module	465213.099.400-05	1	1	1	1	1	1	1	1	1	1		1	1	1	1
Contact control module LU 7.2 (Relay control module)	465213.270.020 (465213.270.030)	1	1	1	1	1	1	1	1	1	1	1	1	1	1	1
Patchcord Crossover Ethernet cat. 5E		1	1	1	1	1	1	1	1	1	1	1	1	1	1	1
Lift unit Service list	465213.270-XX SL	1	1	1	1	1	1	1	1	1	1	1	1	1	1	1
		Lift Unit 7.2														
		-26	-27	-28	-29	-30	-31	-32	-33	-34	-35	-36	-37	-38	-39	-40
Name	Description	Quantity														

Name	Description	Lift Unit 7.2														
		-10	-11	-12	-14	-15	-16	-17	-18	-19	-20	-21	-22	-23	-24	-25
Lift unit	465213.270	1	1	1	1	1	1	1	1	1	1	1	1	1	1	1
Adapter LISA20	465213.160.710-12		1													
Optoadapter 12-110V	465213.060.320								2							
Cable	465213.060.610(-01)	1					1				1		1			1
Cable F-F NFS	465213.060.610-11		1													
Cable DOPPLER	465213.060.670(-01)			1												
Cable DOPPLER+	465213.060.670(-01)			1												
Cable BLT	465213.060.690				1											
Cable F-F NHS	465213.060.610-08					1										
Cable SCHINDLER	465213.060.610-09							1								
Cable BG-15	465213.060.640-01								1							
Cable ORONA	465213.060.910									1						
Cable ARKEL	465213.060.920											1				
Cable F-F DFS	465213.060.610-04														1	
Wiring harness	465213.270.090													1		
Adaptor KLEEMAN BG15	465213.060.280-01								1							
Power adaptor ~220B /+12B 2A		1	1	1	1	1	1	1	1	1	1	1	1	1	1	1
Terminal block	465213.270.050	1	1	1	1	1	1	1	1	1	1	1	1	1	1	1
Wiring Harness	465213.270.060	2	2	2	2	2	2	2	2	2	2	2	2	2	2	2
Screw	B.M3x20 DIN84	2	2	2	2	2	2	2	2	2	2	2	2	2	2	2
Holder	465213.270.002-01	1	1	1	1	1	1	1	1	1	1	1	1	1	1	1
Door sensor	IO 102-2 (MC31)	1	1	1	1	1	1	1	1	1	1	1	1	1	1	1
Adapter LiSA	465213.160.710-12		1													
Buckle	CV-300	2	2	2	2	2	2	2	2	2	2	2	2	2	2	2
Holder	465213.270.002	1	1	1	1	1	1	1	1	1	1	1	1	1	1	1
Intercom unit 7.2	465213.270.500	1	1	1	1	1	1	1	1	1	1	1	1	1	1	1
Intercom module	465213.099.400-05	1	1	1	1	1	1	1	1	1	1	1	1	1	1	1
Wiring harness	465213.270.560	1	1	1	1	1	1	1	1	1	1	1	1	1	1	1
Contact control module LU 7.2 (Relay control module)	465213.270.020 (465213.270.030)	1	1	1	1	1	1	1	1	1	1	1	1	1	1	1
Patchcord Crossover Ethernet cat. 5E		1	1	1	1	1	1	1	1	1	1	1	1	1	1	1
Lift unit Service list	465213.270-XX SL	1	1	1	1	1	1	1	1	1	1	1	1	1	1	1

Name	Description	Lift Unit 7.2														
		-41	-42	-43	-44	-45	-46	-47	-48	-49	-50	-51	-52	-53	-54	-55
Lift unit	465213.270	1	1	1	1	1	1	1	1	1	1	1	1	1	1	1
Optoadapter 12-110V	465213.060.320		2	2+/-					2					3		
Adapter-coupler	465213.160.710-09			1+/-												
Cable MIK-EL	465213.060.930	1														
Cable F-F NHL	465213.060.610-05		1													
Cable F-F NHS	465213.060.610-08			1					1		1					
Cable STVF	465213.060.610-07				1											
Cable F-M	465213.060.610-06					1										
Cable DOPPLER	465213.060.670						1									
Cable	465213.060.610(-01)							1								
Cable F-F NFS	465213.060.610-11									1						
Cable SILVER	465213.060.940											1				
Cable ARKEL	465213.060.920												1			
Wiring harness	465213.270.090													1		
Adapter P313 AUTINOR AC-01	465213.160.410							1								
Interface board SWORD RS232	465213.160.400						1									
Cable E9	465213.060.610-10														1	
Cable ECLIPSE	465213.060.690-01															1
Power adaptor ~220B /+12B 2A		1	1	1	1	1	1	1	1	1	1	1	1	1	1	1
Terminal block	465213.270.050	1	1	1	1	1	1	1	1	1	1	1	1	1	1	1
Wiring Harness	465213.270.060	2	2	2	2	2	2	2	2	2	2	2	2	2	2	2
Screw	B.M3x20 DIN84	2	2	2	2	2	2	2	2	2	2	2	2	2	2	2
Door sensor	IO 102-2 (MC31)	1	1	1	1	1	1	1	1	1	1	1	1	1	1	1
Holder	465213.270.002-01	1	1	1	1	1	1	1	1	1	1	1	1	1	1	1
Buckle	CV-300	2	2	2	2	2	2	2	2	2	2	2	2	2	2	2
Holder	465213.270.002	1	1	1	1	1	1	1	1	1	1	1	1	1	1	1
Intercom unit 7.2	465213.270.500	1	1	1	1	1	1	1	1	1	1	1	1	1	1	1
Intercom module	465213.099.400-05	1	1	1	1	1	1	1	1	1	1	1	1	1	1	1
Wiring harness	465213.270.560	1	1	1	1	1	1	1	1	1	1	1	1	1	1	1
Contact control module LU 7.2 (Relay control module)	465213.270.020 (465213.270.030)	1	1	1	1	1	1	1	1	1	1	1	1	1	1	1
Patchcord Crossover Ethernet cat. 5E		1	1	1	1	1	1	1	1	1	1	1	1	1	1	1
Lift unit Service list	465213.270-XX SL	1	1	1	1	1	1	1	1	1	1	1	1	1	1	1

Name	Description	Lift Unit 7.2														
		-56	-57	-58	-59	-60	-61	-62	-63	-64	-65	-66	-67	-68	-69	-70
Lift unit	465213.270	1	1	1	1	1	1	1	1	1	1	1	1	1	1	1
Cable VASSLER	465213.160.710-03	1														
Cable TMS600	465213.160.710		1													
Cable BETACONTROL	465213.160.710-01			1												
Cable TP	465213.160.710-02				1											
Cable SHK6000	465213.160.720-02					1										
Cable TKL	465213.160.720						1									
Cable SOYUZ	465213.160.720-11							1								
Cable LLC	465213.160.720-05								1							
Cable SHL-R	465213.160.710-05									1						
Cable F-F-DFS	465213.060.610-04										1					
Cable VEK	465213.160.720-03											1				
Cable KOLLMORGEN	465213.160.720-04												1			
Cable THY-CMC/MCI	465213.160.710-06													1		1
Cable SECURLIFT	465213.160.730														1	
Adapter CMC4+	465213.160.270-01														1	
Power adaptor ~220B /+12B 2A		1	1	1	1	1	1	1	1	1	1	1	1	1	1	1
Terminal block	465213.270.050	1	1	1	1	1	1	1	1	1	1	1	1	1	1	1
Wiring Harness	465213.270.060	2	2	2	2	2	2	2	2	2	2	2	2	2	2	2
Screw	B.M3x20 DIN84	2	2	2	2	2	2	2	2	2	2	2	2	2	2	2
Door sensor	IO 102-2 (MC31)	1	1	1	1	1	1	1	1	1	1	1	1	1	1	1
Holder	465213.270.002-01	1	1	1	1	1	1	1	1	1		1	1	1	1	1
Buckle	CV-300	2	2	2	2	2	2	2	2	2		2	2	2	2	2
Holder	465213.270.002	1	1	1	1	1	1	1	1	1	1	1	1	1	1	1
Intercom unit 7.2	465213.270.500	1	1	1	1	1	1	1	1	1		1	1	1	1	1
Intercom module	465213.099.400-05	1	1	1	1	1	1	1	1	1		1	1	1	1	1
Wiring harness	465213.270.560	1	1	1	1	1	1	1	1	1		1	1	1	1	1
Contact control module LU 7.2 (Relay control module)	465213.270.020 (465213.270.030)	1	1	1	1	1	1	1	1	1	1	1	1	1	1	1
Patchcord Crossover Ethernet cat. 5E		1	1	1	1	1	1	1	1	1	1	1	1	1	1	1
Lift unit Service list	465213.270-XX SL	1	1	1	1	1	1	1	1	1	1	1	1	1	1	1

Name	Description	Lift Unit 7.2															
		-71	-72	-73	-74	-75	-76	-77	-78	-79	-80	-81	-82	-83	-84	-85	-86
		Quantity															
Lift unit	465213.270	1	1	1	1	1	1	1	1	1	1	1	1	1	1	1	1
Cable WIPO	465213.160.710-07	1															
Cable KLST	465213.160.720-06		1														
Cable ELCO MICRO	465213.160.710-08			1													
Cable ARKEL	465213.060.920				1												1
Cable BL6	465213.160.730-01					1											
Cable WEBER	465213.160.710-10						1										
Cable GTE	465213.160.710-11							1									
Cable DAESUNG	465213.160.730-02								1								
Cable ML65X	465213.160.720-07									1							
Cable ISL	465213.160.730-03											1					
Cable ML60X	465213.160.710-13												1				
Cable F-F-NHS	465213.060.610-08													1			
Cable SCHINDLER SX	465213.160.710-14														1		
Cable ML50S	465213.160.730-04															1	
Cable	465213.060.610(-01)											1					
Power adaptor ~220B /+12B 2A		1	1	1	1	1	1	1	1	1	1	1	1	1	1	1	1
Terminal block	465213.270.050	1	1	1	1	1	1	1	1	1	1	1	1	1	1	1	1
Wiring Harness	465213.270.060	2	2	2	2	2	2	2	2	2	2	2	2	2	2	2	2
Screw	B.M3x20 DIN84	2	2	2	2	2	2	2	2	2	2	2	2	2	2	2	2
Door sensor	IO 102-2 (MC31)	1	1	1	1	1	1	1	1	1	1	1	1	1	1	1	1
Holder	465213.270.002-01	1	1	1	1	1	1	1	1	1	1	1	1	1	1	1	1
Buckle	CV-300	2	2	2	2	2	2	2	2	2	2	2	2	2	2	2	2
Holder	465213.270.002	1	1	1	1	1	1	1	1	1	1	1	1	1	1	1	1
Intercom unit 7.2	465213.270.500	1	1	1	1	1	1	1	1	1	1	1	1	1	1	1	1
Intercom module	465213.099.400-05	1	1	1	1	1	1	1	1	1	1	1	1	1	1	1	1
Wiring harness	465213.270.560	1	1	1	1	1	1	1	1	1	1	1	1	1	1	1	1
Contact control module LU 7.2 (Relay control module)	465213.270.020 (465213.270.030)	1	1	1	1	1	1	1	1	1	1	1	1	1	1	1	1
Patchcord Crossover Ethernet cat. 5E		1	1	1	1	1	1	1	1	1	1	1	1	1	1	1	1
Lift unit Service list	465213.270-XX SL	1	1	1	1	1	1	1	1	1	1	1	1	1	1	1	1

Name	Description	Lift Unit 7.2															
		-87	-88	-89	-90	-91	-92	-93	-94	-95	-96	-97	-98	-99	-100	-101	-102
Lift unit	465213.270	1	1	1	1	1	1	1	1	1	1	1	1	1	1	1	1
Relay control unit	465213.270.030									1							
Intercom unit AP	465213.270.350									1							
Landing intercom	465213.300.100									2 ⁴							
Optoadapter 12-110V	465213.060.320									3							
Cable F-F-NHL	465213.060.610-05	1														1	
Cable HYUNDAI CAN	465213.160.730-05		1														
Cable ARKEL	465213.060.920			1	1			1									
Cable HIDRAL	465213.160.730-08					1											
Cable MITSUBISHI	465213.160.730-09						1										
Cable ML60X	465213.160.710-13								1			1					
Cable	465213.060.610																1
Cable GMV	465213.160.730-12									1							
Cable GTE	465213.160.710-11											1					
Cable	465213.060.630												1				
Cable DIGILIFT	465213.160.730-13													1			
Wiring harness	465213.270.090									1							
Power adaptor ~220B /+12B 2A		1	1	1	1	1	1	1	1	1	1	1	1	1	1	1	1
Terminal block	465213.270.050	1	1	1	1	1	1	1	1	1	1	1	1	1	1	1	1
Wiring Harness	465213.270.060	2	2	2	2	2	2	2	2	2	2	2	2	2	2	1	2
Screw	B.M3x20 DIN84	2	2	2	2	2	2	2	2	2	2	2	2	2	2	2	2
Door sensor	IO 102-2 (MC31)	1	1	1	1	1	1	1	1	1	1	1	1	1	1	1	1
Holder	465213.270.002-01	1	1	1	1	1	1	1	1	1	1	1	1	1	1	1	1
Buckle	CV-300	2	2	2	2	2	2	2	2	2	2	2	2	2	2	2	2
Holder	465213.270.002	1	1	1	1	1	1	1	1	1	1	1	1	1	1	1	1
Intercom unit 7.2	465213.270.500	1	1	1	1	1	1	1	1	1	1	1	1	1	1	1	1
Intercom module	465213.099.400-05	1	1	1	1	1	1	1	1	1	1	1	1	1	1	1	1
Wiring harness	465213.270.560	1	1	1	1	1	1	1	1	1	1	1	1	1	1	1	1
Contact control module LU 7.2 (Relay control module)	465213.270.020 (465213.270.030)	1	1	1	1	1	1	1	1	1	1	1	1	1	1	1	1
Patchcord Crossover Ethernet cat. 5E		1	1	1	1	1	1	1	1	1	1	1	1	1	1	1	1
Lift unit Service list	465213.270-XX SL	1	1	1	1	1	1	1	1	1	1	1	1	1	1	1	1

		Lift Unit 7.2																
		-103	-104	-105	-106	-107	-108	-109	-110	-111	-112	-113	-114	-115	-116	-117	-118	-119
Name	Description	Quantity																
Lift unit	465213.270	1	1	1	1	1	1	1	1	1	1	1	1	1	1	1	1	1
Cable KRONA	465213.160.730-14	1																
Cable ARKEL	465213.060.920		1				1						1				1	
Cable GTE	465213.160.710-11			1					1							1		
Cable INVT	465213.160.710-15				1													
Cable GPS	465213.160.710-16					1												
Cable	465213.060.610							1										
Cable HIDRA CRONO	465213.160.730-17									1								
Cable CPU100	465213.160.730-19													1				
Cable THYSEN GEC	465213.160.730-20														1			
Cable VIMEC E10	465213.160.720-08											1						
Cable PLK	465213.160.710-16																	1
Cable F-F-NHS	465213.060.610-08										1							
Adapter P313 AUTINOR AC-01	465213.160.410					1												
Power adaptor ~220B /+12B 2A		1	1	1	1	1	1	1	1	1	1	1	1	1	1	1	1	1
Terminal block	465213.270.050	1	1	1	1	1	1	1	1	1	1	1	1	1	1	1	1	1
Wiring Harness	465213.270.060	2	2	2	2	2	2	2	2	2	2	2	2	2	2	1	2	2
Screw	B.M3x20 DIN84	2	2	2	2	2	2	2	2	2	2	2	2	2	2	2	2	2
Door sensor	IO 102-2 (MC31)	1	1	1	1	1	1	1	1	1	1	1	1	1	1	1	1	1
Holder	465213.270.002-01	1	1	1	1	1	1	1	1	1	1	1	1	1	1	1	1	1
Buckle	CV-300	2	2	2	2	2	2	2	2	2	2	2	2	2	2	2	2	2
Holder	465213.270.002	1	1	1	1	1	1	1	1	1	1	1	1	1	1	1	1	1
Intercom unit 7.2	465213.270.500	1	1	1	1	1	1	1	1	1	1	1	1	1	1	1	1	1
Intercom module	465213.099.400-05	1	1	1	1	1	1	1	1	1	1	1	1	1	1	1	1	1
Wiring harness	465213.270.560	1	1	1	1	1	1	1	1	1	1	1	1	1	1	1	1	1
Contact control module LU 7.2 (Relay control module)	465213.270.020 (465213.270.030)	1	1	1	1	1	1	1	1	1	1	1	1	1	1	1	1	1
Patchcord Crossover Ethernet cat. 5E		1	1	1	1	1	1	1	1	1	1	1	1	1	1	1	1	1
Lift unit Service list	465213.270-XX SL	1	1	1	1	1	1	1	1	1	1	1	1	1	1	1	1	1

Notes:

1. Cable 465213.060.610-01 (10m) supplied for machine roomless lifts.
2. Not supplied with installation set.
3. Options 465213.060.670 or 465213.060.670-01 can be supplied on demand
4. In dependence on option there can be supplied with 465213.270.400 or 465213.300.150).

Codes: "-" - not supplied, "+/-" – supplied on demand, "XX" – LU option

		Lift Unit 7.2													
		-120	-121	-122	-123	-124									
Name	Description	Quantity													
Lift unit	465213.270-...	1	1	1	1	1									
Optoadaptor 12-110V	465213.060.320			1											
Cable MODEUN	465213.160.730-22	1													
Cable ARKEL	465213.060.920					1									
Cable CUANGRI	465213.160.730-23		1												
Cable KONE KCE	465213.160.730-24			1											
Cable BLT	465213.060.690				1										
Cable HIDRA CRONO	465213.160.730-17														
Cable CPU100	465213.160.730-19														
Cable THYSSEN GEC	465213.160.730-20														
Cable VIMEC E10	465213.160.720-08														
Cable PLK	465213.160.710-16														
Cable F-F-NHS	465213.060.610-08														
Adapter P313 AUTINOR AC-01	465213.160.410														
Power adaptor ~220B /+12B 2A		1	1	1	1	1									
Terminal block	465213.270.050	1	1	1	1	1									
Wiring Harness	465213.270.060	2	2	2	2	2									
Screw	B.M3x20 DIN84	2	2	2	2	2									
Door sensor	IO 102-2 (MC31)	1	1	1	1	1									
Holder	465213.270.002-01	1	1	1	1	1									
Buckle	CV-300	2	2	2	2	2									
Holder	465213.270.002	1	1	1	1	1									
Intercom unit 7.2	465213.270.500	1	1	1	1	1									
Intercom module	465213.099.400-05	1	1	1	1	1									
Wiring harness	465213.270.560	1	1	1	1	1									
Contact control module LU 7.2 (Relay control module)	465213.270.020 (465213.270.030)	1	1	1	1	1									
Patchcord Crossover Ethernet cat. 5E		1	1	1	1	1									
Lift unit Service list	465213.270-XX SL	1	1	1	1	1									

Notes:

1. Cable 465213.060.610-01 (10m) supplied for machine roomless lifts.
2. Not supplied with installation set.
3. Options 465213.060.670 or 465213.060.670-01 can be supplied on demand
4. In dependence on option there can be supplied with 465213.270.400 or 465213.300.150).

Codes: "-" - not supplied, "+/-" – supplied on demand, "XX" – LU option

APPENDIX C

LU 7.2 input/output types and their usage

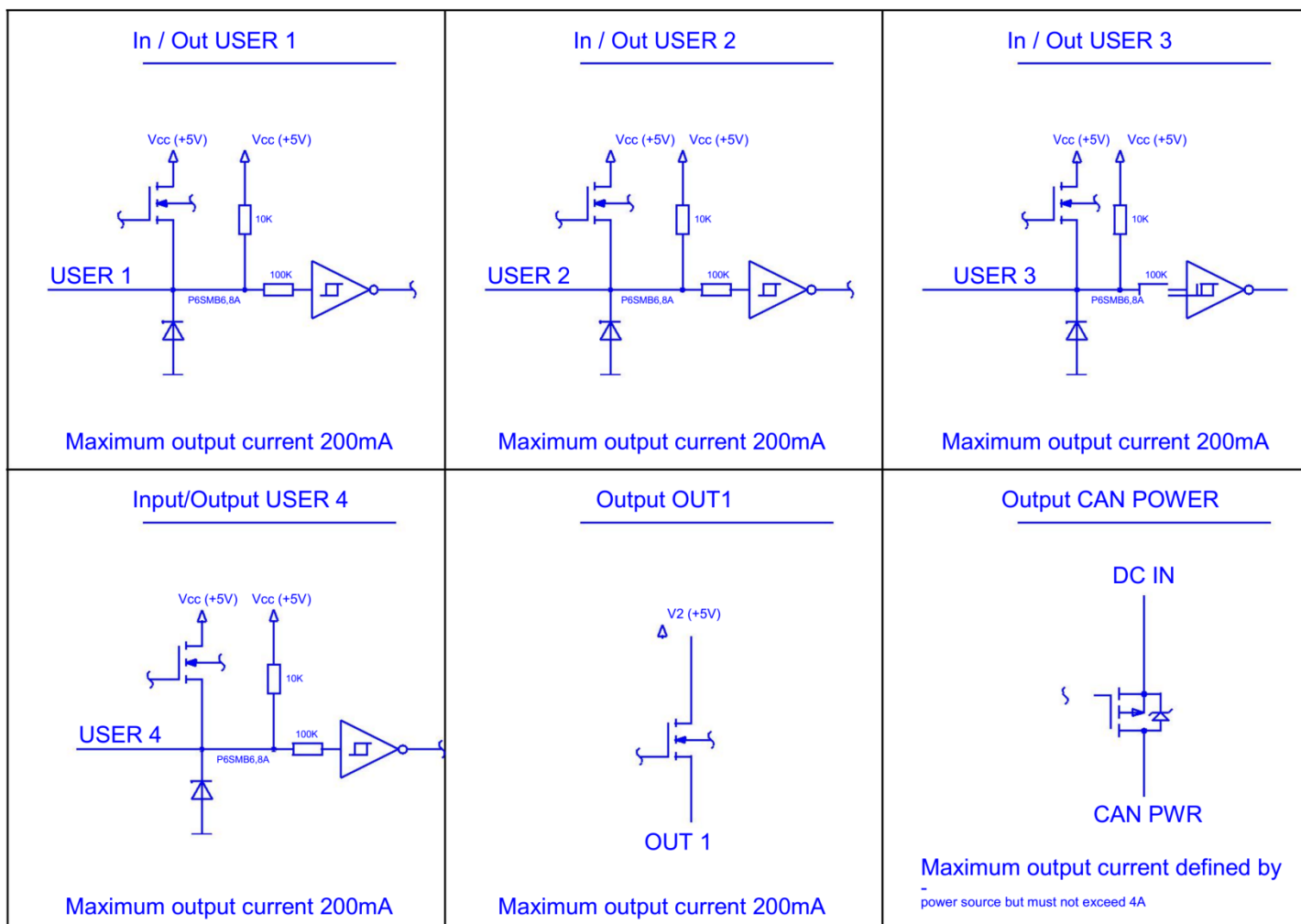

APPENDIX D

Voice notification possible combination

Type of the voice notification in lift cabin				The value of LU EEPROM address 14
Voice signal	Audio notification	Floor arrival notification	Sound accompaniment	
No	No	No	No	0
Yes	No	No	No	1
No	Yes	No	No	2
Yes	Yes	No	No	3
No	No	Yes	No	4
Yes	No	Yes	No	5
No	Yes	Yes	No	6
Yes	Yes	Yes	No	7
No	No	No	Yes	8
Yes	No	No	Yes	9
No	Yes	No	Yes	10
Yes	Yes	No	Yes	11
No	No	Yes	Yes	12
Yes	No	Yes	Yes	13
No	Yes	Yes	Yes	14
Yes	Yes	Yes	Yes	15

APPENDIX E

Correspondence of interface cards to Lift Unit 7.2 options

Interface board	Lift Unit option	Part Number
UBK CM3	-10 «P», -21 «ЭСК», -38 «ТР», -53 «ИНВ».	(465213.160.200-01)
OTIS CM3	-11 «OTIS».	(465213.160.210)
RS485 CM3	-14 «ШУЛК-32», -17 «УУЛ», -19 «СУЛ», -25 «СПУЛ», -26 «ОЛИМП», -35 «НКУ-МППЛ БПШ-2», -44 «HYUNDAI», -55 «ECLIPSE», -60 «ШК6000», -61 «ТКЛ», -66 «VEK», -77 «GTE», -81 «ISL», -82 «ML60X», -94 «GILAN», -97 «МЛК», -98 «TRAVIS», -119 «PLK»	(465213.160.240-01)
SODIMAS	-18 «SODIMAS», -40 «DMG», -47 «AC-01», -54 «E9», -62 «СОЮЗ», -73 «ELCO MICRO», -85 «ML50S».	(465213.160.260)
RS232 CM3	-20 «LG», -22 «AXEL», -24 «THYSSEN», -27 «KLEEMANN», -28 «DOPPLER», -30 «EXPRESS», -31 «THYSSEN TAC50», -32 «SCHINDLER», -33 «BG-15», -37 «SODIMAS QI», -39 «ORONA ARCA1», -42 «KONE», -43 «VEGA», -45 «NICE», -46 «S9», -48 «iAStar», -49 «FST2», -50 «CANNY», -56 «VASSLER», -58 «BETACONTROL», -67 «KOLLMORGEN», -68 «THYSSEN CMC», -70 «THYSSEN MCI», -75 «BL6», -76 «WEBER», -80 «SKG», -83 «PDAHL S3», -84 «SCHINDLER SX», -87 «MASHIBA», -91 «HIDRAL», -96 «GMV», -100 «DIGILIFT».	(465213.160.270)
KONE	-57 «TMS600».	(465213.160.290)
CAN CM3	-23 «ELEX», -29 «BLT», -34 «ORONA ARCA2», -36 «ARKEL», -41 «MIK-EL», -51 «SILVER», -52 «DOPPLER ACT», -63 «LLC», -65 «FT9x0», -69 «SECURLIFT», -71 «WIPO», -72 «KLST», -74 «KOYO», -78 «DAESUNG», -79 «ML65X», -86 «MP VIASERIE», -88 «HYUNDAI CAN», -89 «IMEM», -90 «BST», -92 «MITSUBISHI», -93 «EASY TRONIC», -118 «BR100», -120 «MODEUN», -121 «GUANGRI», -123 «IFE», -124 «EAGLE»	(465213.160.300-01)
Loop current	-59 «CARLOS SILVA», -64 «ШЛ-Р».	(465213.160.310)